

www.vc4p.com

شهر مجازی پارسیان



فرهنگ

لغات اتومبیل

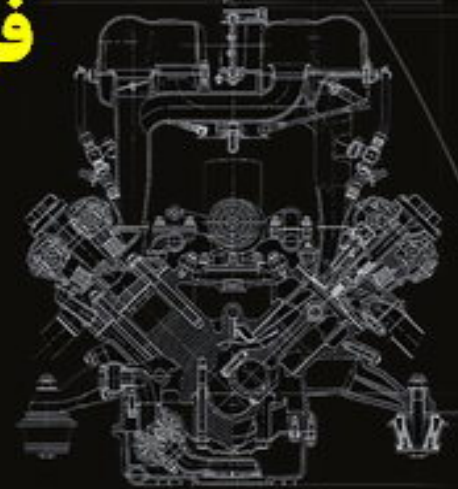

نویسنده : مسعود صادقی

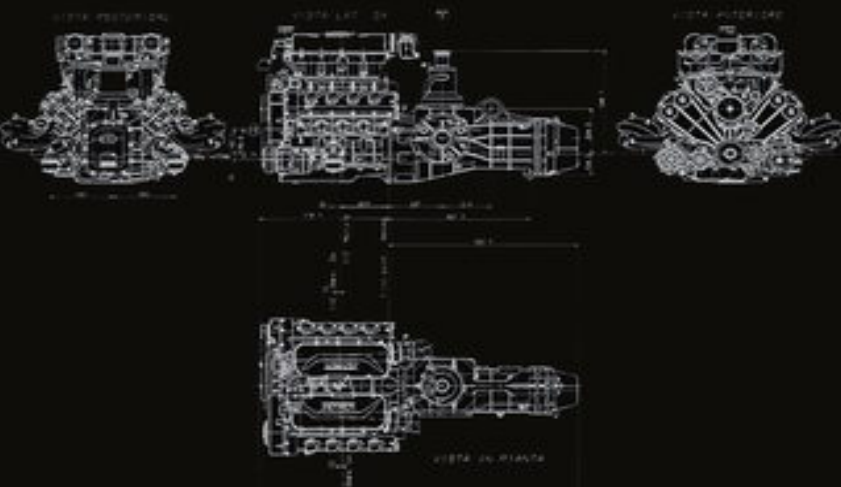

شناسنامه کتاب :

نویسنده : مسعود صادقی

ناشر : شهر مجازی پارسیان

نوبت چاپ : اول / بهار ۸۵

کلیه حقوق این اثر متعلق به مسعود صادقی از شهر مجازی پارسیان می باشد و هیچ بخشی از این اثر بدون مجوز نویسنده و شهر مجازی پارسیان قابل چاپ ، توزیع و یا کپی برداری نمی باشد.

.....
..... A
..... B
..... C
..... D
..... E
..... F
..... G
..... H
..... I
..... J
..... K
..... L
..... M
..... N
..... O
..... P
..... R
..... S
..... T
..... U
..... V
..... W
.....
.....



ششقل مجازی چار سیجان

Race

A

4WD :
Four wheel drive

16V :
) 16 16 valve ,

↓ (DOHC , SOHC

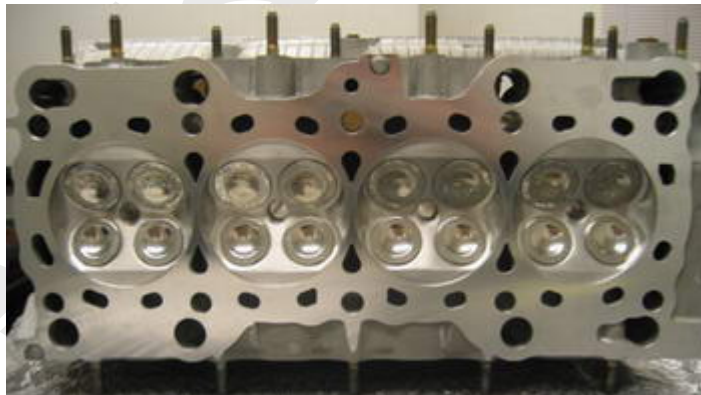

1 DIN :
1,12 sae

1 KW :
1,34 ece

1 KW :
1,35 PSdin

A :

.

ABAT-VENT :
Speedster

ABAXIAL :

ABC :
Active Body Control.

). (body roll)

(

ABS :
Anti Blocker System.

(.)

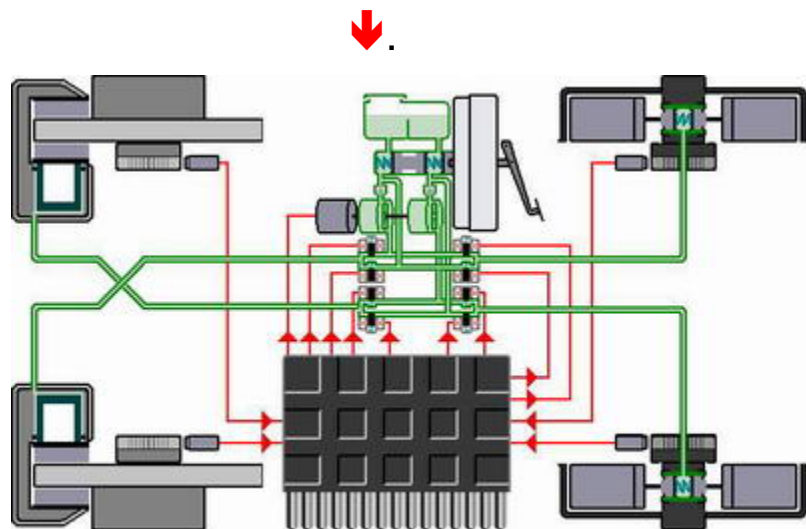

AC :
air condition



ACC :
Adaptive Cruise Control

DaimlerChrysler

ACEA :

ADB :
Automatische Differential Bremse.

ADEZYON :

AERODINAMIK :

0.45 SUV

$c_w=0,26$

ABC

AFS :
Active Fahrwerks Stabilierung.

Citroen Xantia Activa

AIRBAG :

↓
Optimized Airbag Control from Bosch

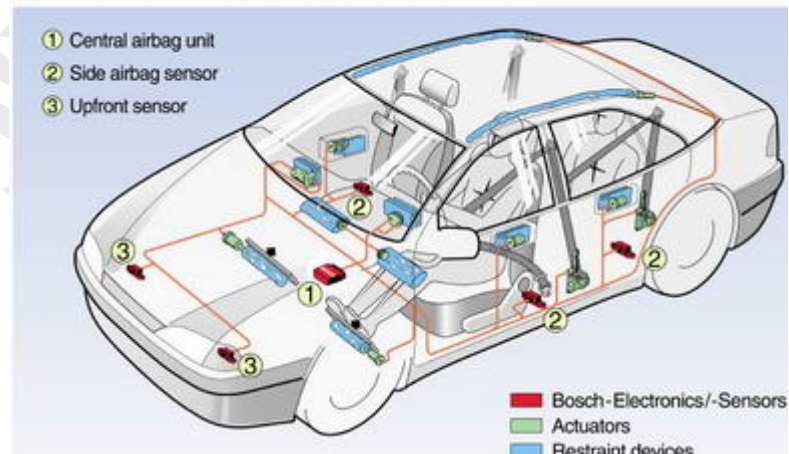

Air Filter :

ECU

Air Flow Meter :

AQUA PLANNING :

Acceleration :

ABS , ESP ,

Active Safety :

ABS.

ALB :
Anti Lock Brakes.

AMPERMETR :

Anti Freez :

%50

%50

BMW

ASC+T :
Automatische Stabilitats Control+Traktion.

ASC+T

ASR :
Anti Slip Regulation Anti-Schlupf-Regelung

.ASR

Traction Control

TSC. ETC , TC

ATF :

AWD :
All Wheel Drive

(

AWS :
All Wheel Steering.

AUTODIMMING :

B

BAS :

benzene :

C₆H₆

BI-LITRONIC :

BOSCH .

Xenon

BI-XENON :

BI-XENON

XENON

BLOW-BY :

Brake Disk Wiping :

BOXER MOTOR :

V

(ECU)

C

CAN :
Controller Area Network.

(.... ABS , AIRBAG ,)

CABRIO :

+



Catalyzer :

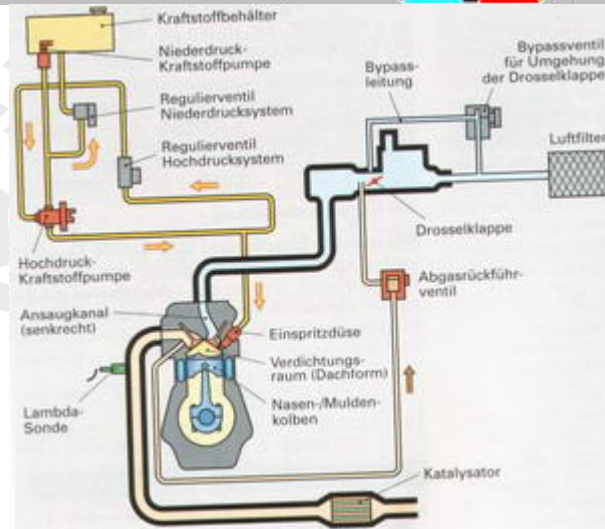
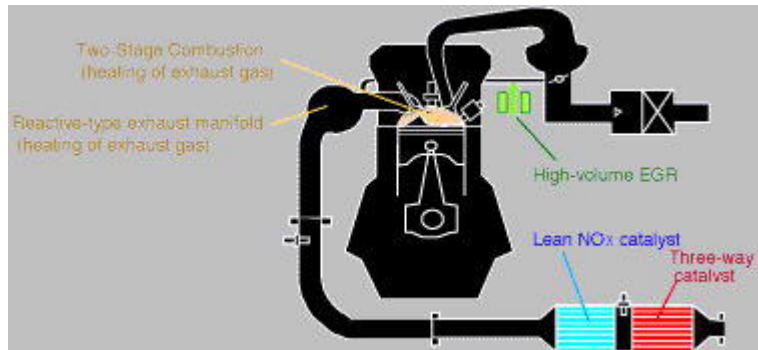

CBC :

Cornering Brake Control.

ESP

BMW

CBC

. CBC

CC :
Cubic Centimetre.

) ()
(Cubic Inch16 CC 1). (

.CDI CDI :
Daimler-Chrysler

↓ Common Rail Diesel Injection System

Common Rail System for 8-Cylinder Passenger Car Diesel Engines

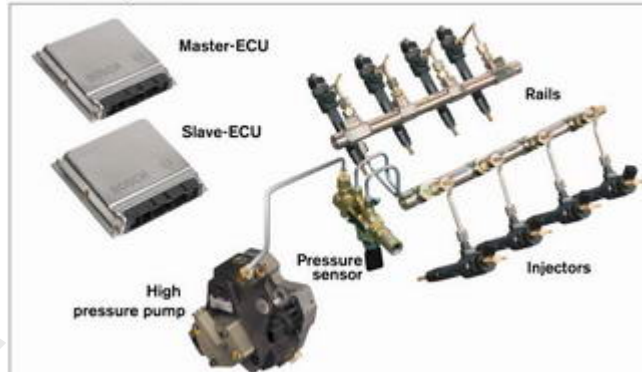

Bosch Common Rail System for Passenger Cars

- ① Air mass meter
- ② Engine ECU
- ③ High pressure pump
- ④ Common rail
- ⑤ Injectors
- ⑥ Engine speed sensor
- ⑦ Coolant temp. sensor
- ⑧ Filter
- ⑨ Accelerator pedal sensor

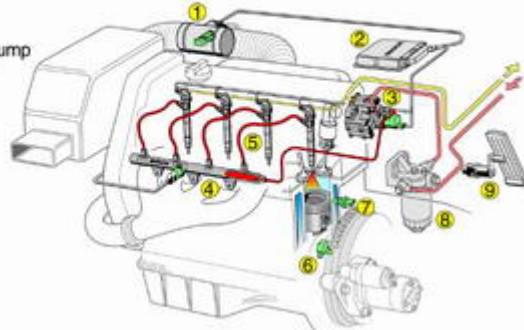

Ceramic :
Porsche Turbo Mercedes CL 55 AMG



.

.....

clutch :

(manual)

()

compressor :

.Jaguar ,

COUPE :

C A

Cryogen Tank :

مشغل مجازی چارسیان

CRS :
.Common Rail System



Diesel-Einspritzsysteme von Bosch

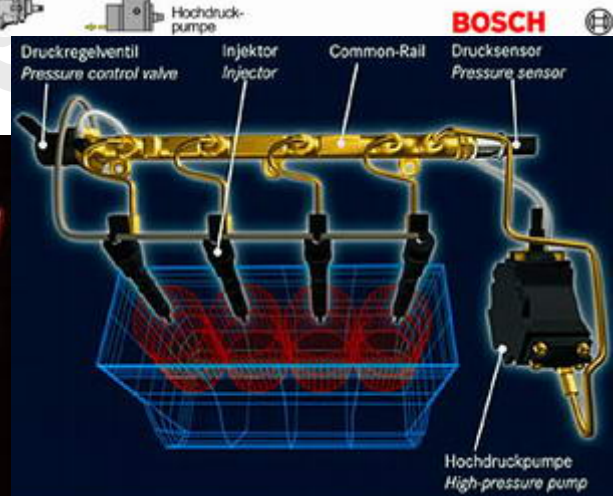
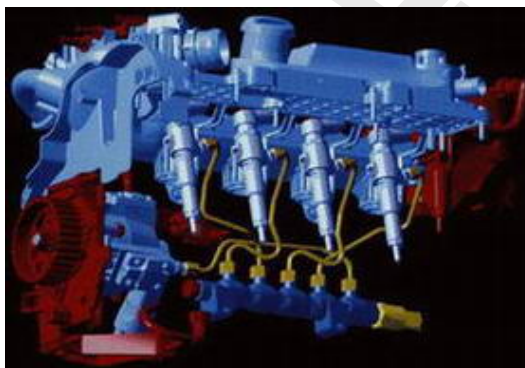
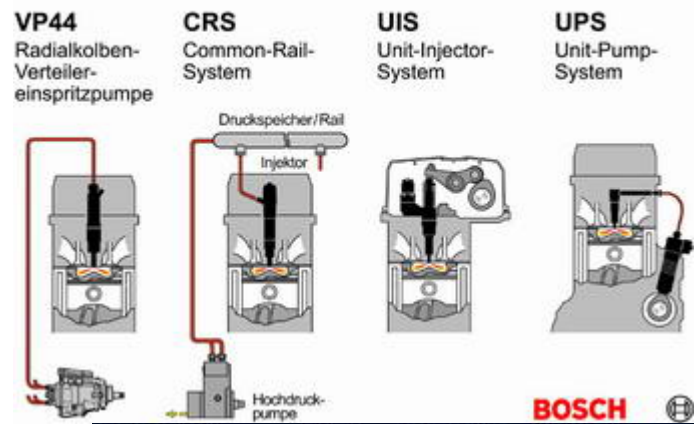

CO :

CRUISE CONTROL :



(CC) 16.3870641 Cubic Inch Cubic Inch :

CVT :
Constantly Variable Transmission.
Van Doorne

Volvo, Kia CVVT :
Continuously Variable Valve Timing,
Hyundai

CW :
()

cylinder :

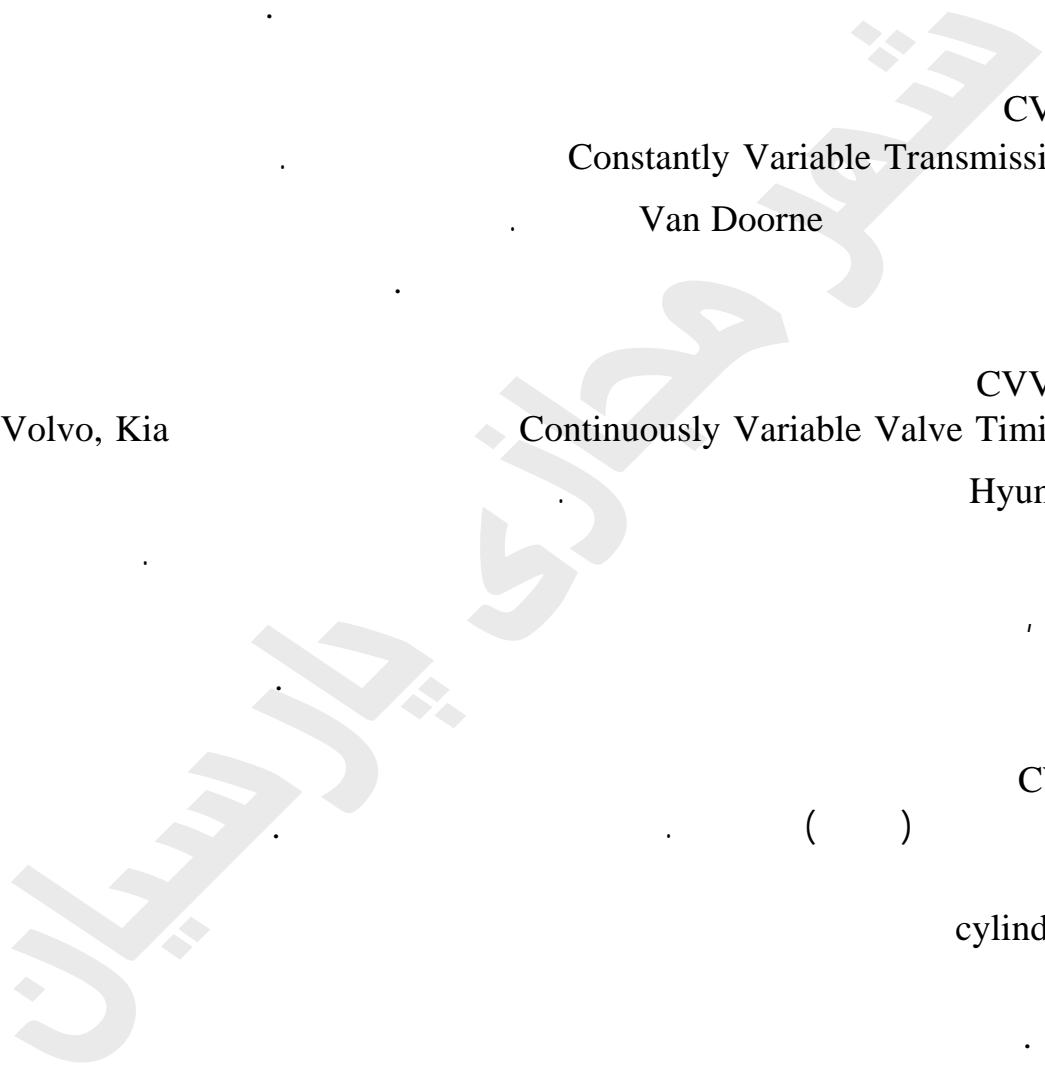

D

D4 :

D4D :

DATENBUS :

CL

DE DION SYSTEM :
DE DION

Detention :

()

deflector :

DI :
Direct Injection.

Audi
↓

Diesel DI systems by Bosch

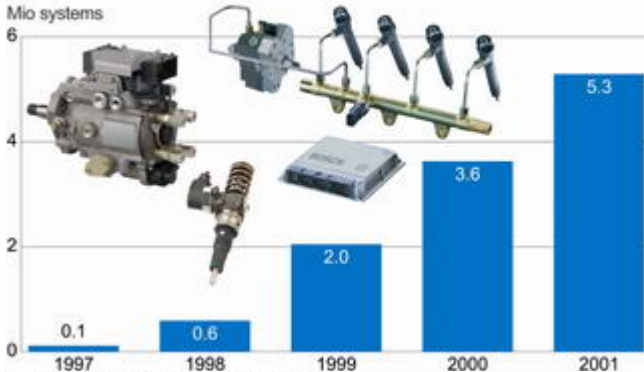

Gasoline Direct Injection (BDE) by Bosch

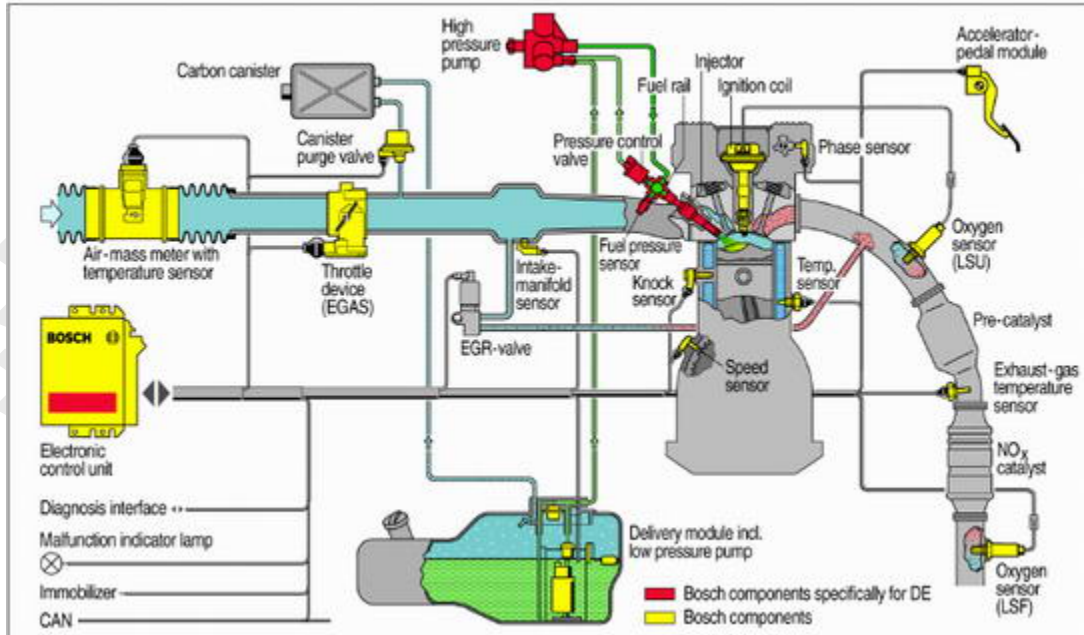

Components of gasoline direct injection from Bosch

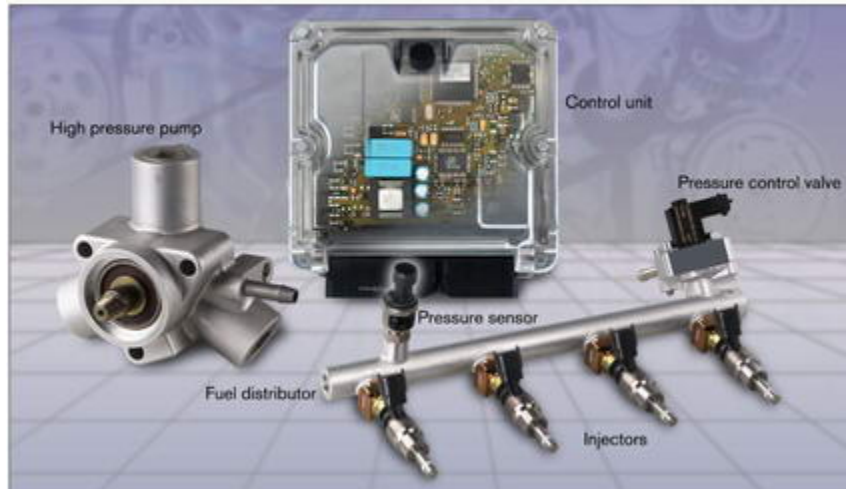

differential :

differential lock :



پارسی چارسیان

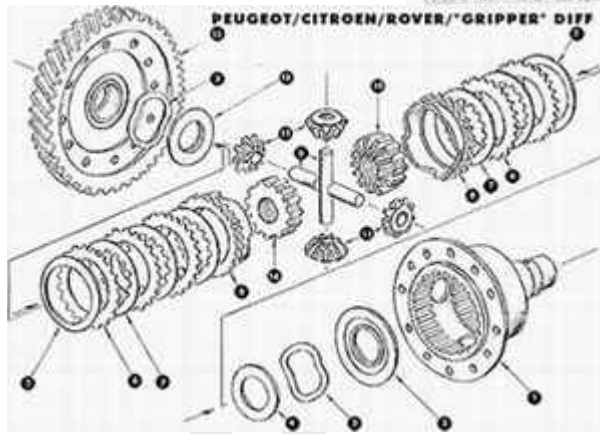
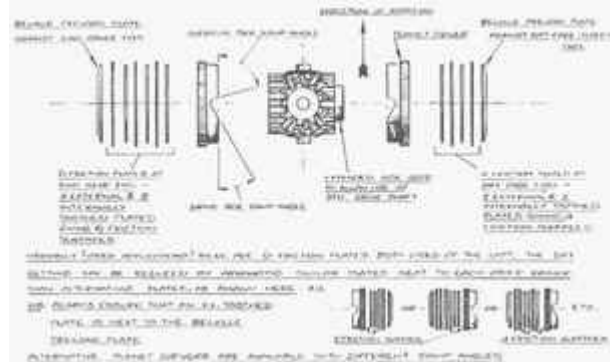

DIN= 1.12 SAE 1 .

DIN :
(Deutsches Institut für normung)

Dynamometr :

Distributor :

DTR :

DISTRONIC) (DYSTRONIC

(Department of US Transportation)
DOT3, DOT4,

DOT :

DOT

DOT5

DOHC :
Double Over Head Camshaft

BMW. (DSC :
ESP)

DSP :
Dynamic Shift program

() ESP
DSTC :
Dynamic Stability and Traction Control.

DSTC volvo () ASR (

DUMMY :

E

ABS

. EBD

EBD-EBV :

ECE :
Economic Commission for Europe

ECOTEC :

OPEL

EDC :
Electronic Diesel Control ,

Unit Injector System (UIS) for Passenger Car Diesel Engines

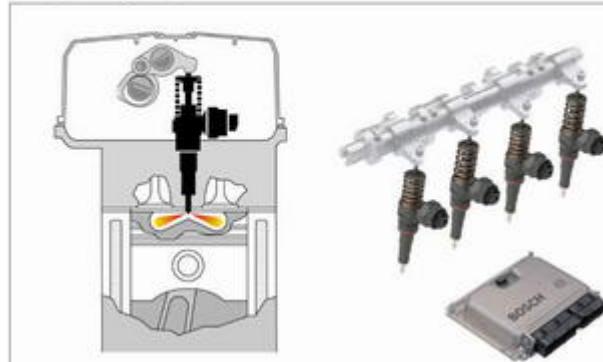

EDLS :

E-gaz :

.()

EHB :

EMV :

EPS :
Elektro Power Steering.

EON :
Enhanced Other Network ,

ESP :
Electronic Stability Program.)

ABS)TSC (ESP ABS)(

ESP

oversteer understeer



Electronic Stability Program (ESP)

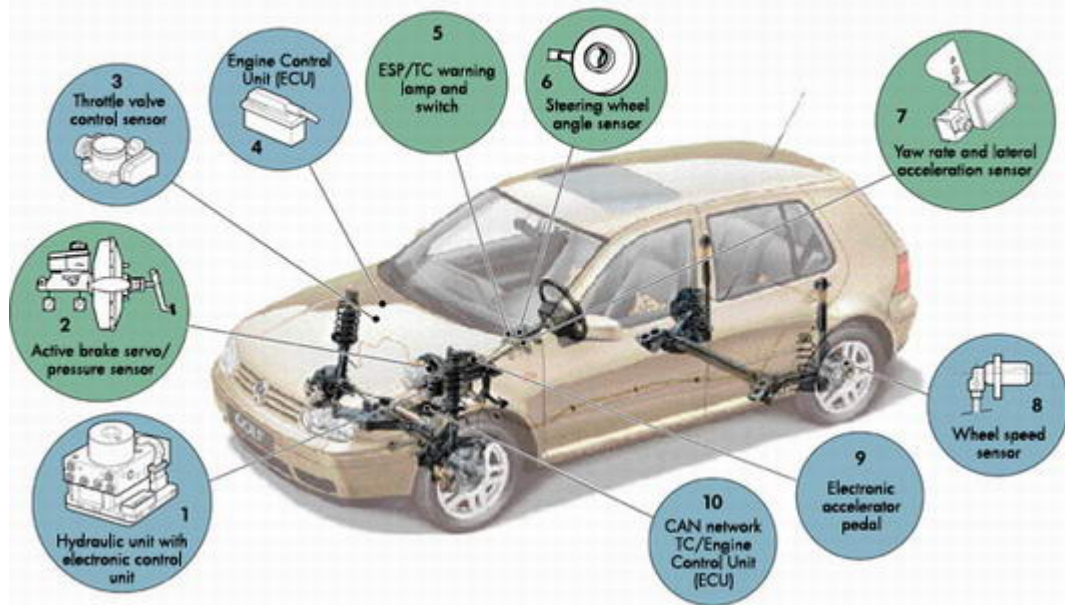

ETC :
Electronic Traction control

ETS :
ASR Electronic Stability System

EURO NCAP :
European New Car Assessment Programme

).

(...)

F

FACE LIFT :

()

FADING :

()

FAN :

%

() FAN

FAN



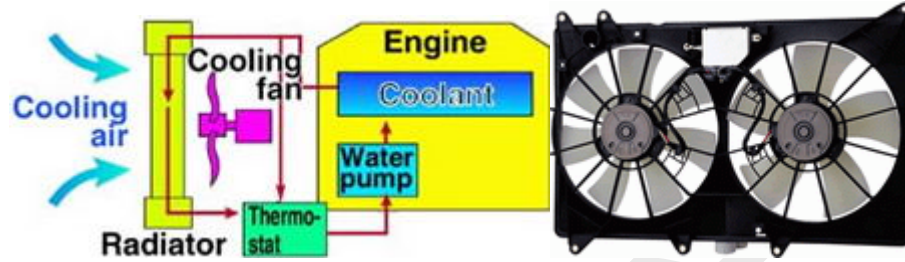

FIS :

FLOATING CAR DATA :

FPS :

FSI :

Volkswagen. () direct injection



Audi 2.0 FSI

Benzin-Direkteinspritzung
direct-injection petrol engine
08/01



Homogenbetrieb
Homogeneous operation



Schichtladebetrieb
Stratified charge operation



Hauptbetriebsarten FSI-Motor



Schichtladebetrieb



Homogenbetrieb

شیپان

Abgasnachbehandlung FSI-Motor

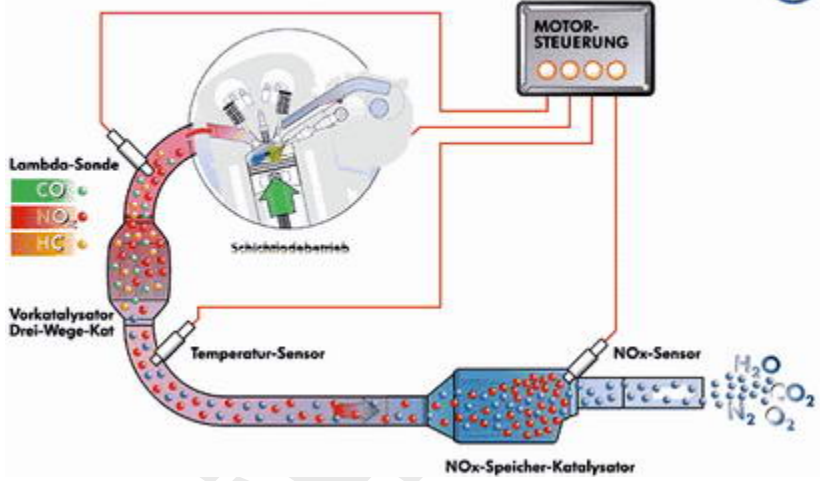

Abgasnachbehandlung FSI-Motor

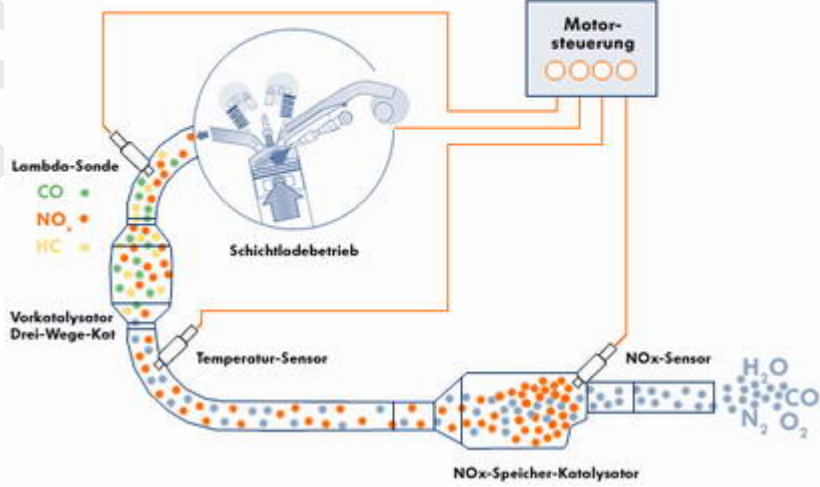

شیراز



Katalysatorregeneration FSI-Motor

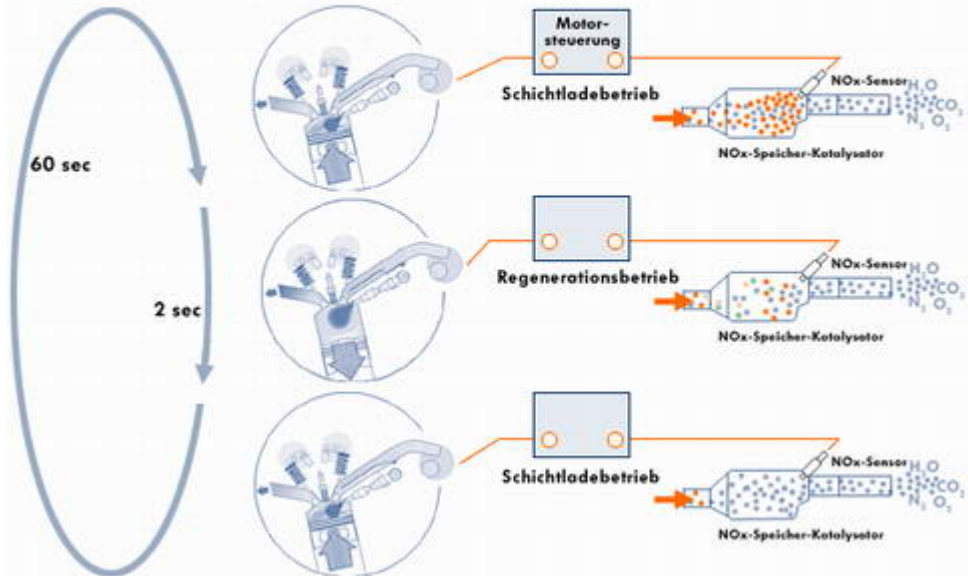

Katalysatorregeneration FSI Motor.

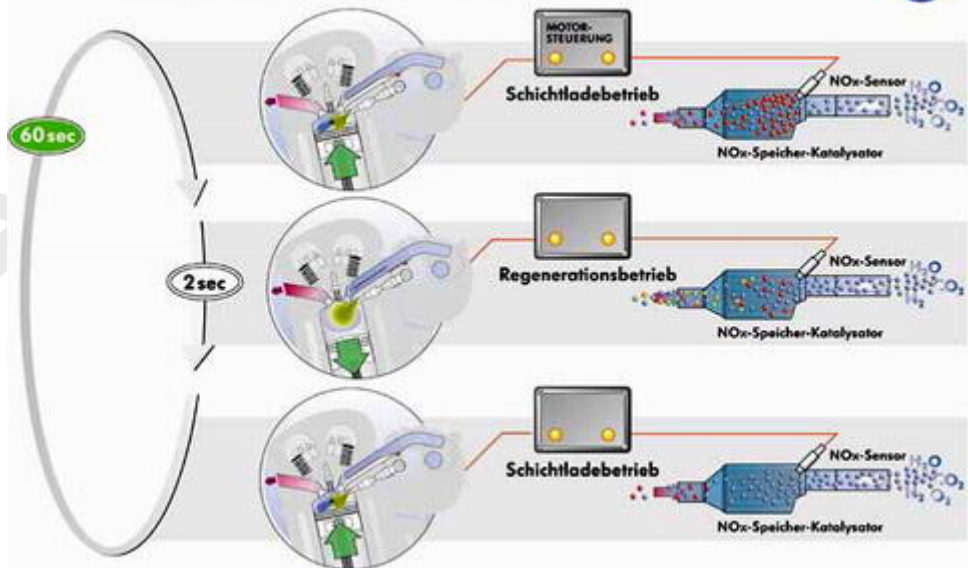

G

Gaz Generator :
AIR BAG (

generator :

GDI :
Direct Injection

GPS :
Global Positioning System

GRIP :

GT :
() Gran Turismo

H

HALDEX :

HARDTOP :

B

cabrio

HARDTOP

Stop

HATCHBACK :

HC :

WD 4

.HDC

HDC :
Hill Descent Control

(
rail common

HDI :
)High Pressure Direct Injection



Diesel-Einspritzsysteme von Bosch

VP44
Radialkolben-
Verteiler-
einspritzpumpe

CRS
Common-Rail-
System

UIS
Unit-Injector-
System

UPS
Unit-Pump-
System

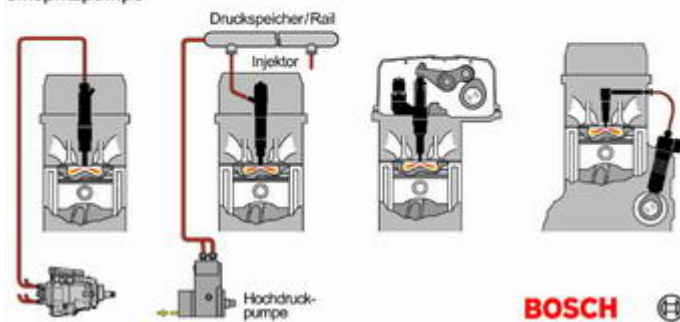

0.7457

Horse Power :

HYBRID :

HYDROPNOMATIK :

(citroen xantia)

HILL HOLD CONTROL :

HUD :
Heads-up Display

(BMW) .

I

I-DRIVE :

BMW

Joystick

IMMOBILIZER :

IMMOBILIZER

ECU

INTERCOOLER :



ISOFIX :

J

Jet Number :

0

JIS :
jis=din) Japanese Industrial Standart

K

Kickdown :

(SAE)

0.735499

(DIN)

KW :
Kilowatt .
0.7496999

L

LED :
Light Emitting Diode.

LED

LED

LEV :
Low Emission Vehicle Standarts.

LEV II

LPG :
Liquified Petroleum Gas

LSD :
Limited Slip Differential

دفتر مجازی چار سیپان

M

MACPHERSON :
MacPherson ,

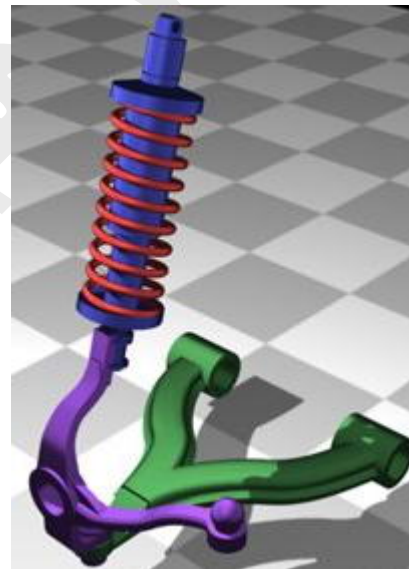

Micro Filter :

MPV :

(Opel Zafira)

MPI :

MOTRONIC :

()

MOZ

ROZ

MOZ :

MSR :
Motor Schleppmomenten Regelung
(ASC)

N

NM

(torque

NM :
)NEWTONMETRE

Navigation System :

NIGHT VISION :

NITRO :
nitromethane.

1.7

14.7

مشغل مجازی چار سیپان

O



Result of Oversteer. When a car oversteers, the front tires have more traction than the rears. The nose wants to point toward the inside of the turn, and the tail wants to slide to the outside.

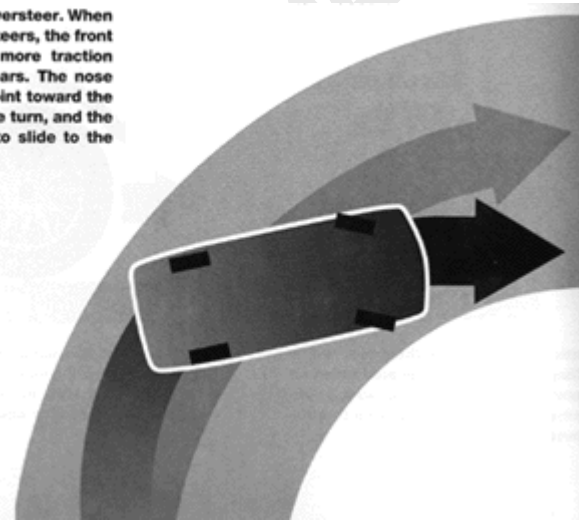

Oversteer :

P

Keith Wiggins

Pacific :



Paddock :

PIT STOP

Palmer, Jonathan :

Grand Prix

Skoal Bandit,

Tyrrell Zakspeed

Panis, Oliver :

Ligier

Elf Racing

...

Ligier Prost

McLaren

Patrese, Riccardo :

grand prix

Shadow

Arrows, Parmalat Brabham, Benetton Alfa Romeo, Williams

Benetton

Paul, Ricard :

Grand Prix

V10

Sauber

Petronas :

Sauber

Peterson, Ronnie :

Peugeot :

McLaren

Prost

Jordan

Prost Jordan

PIT STOP.

PIT STOP

Pitlane :

Pitstop :

PITSTOP

PIT

Pole Position :

lap qualify

Porsche :

V6

McLaren

TAG-McLaren

Postlethwaite, Harvey :

Honda Tyrrell Postlethwaite

Prost :

.Alain Prost

senna

Prost

Ligier

R

Radiotelephone :

Car Audio set

Radiator :



FAN

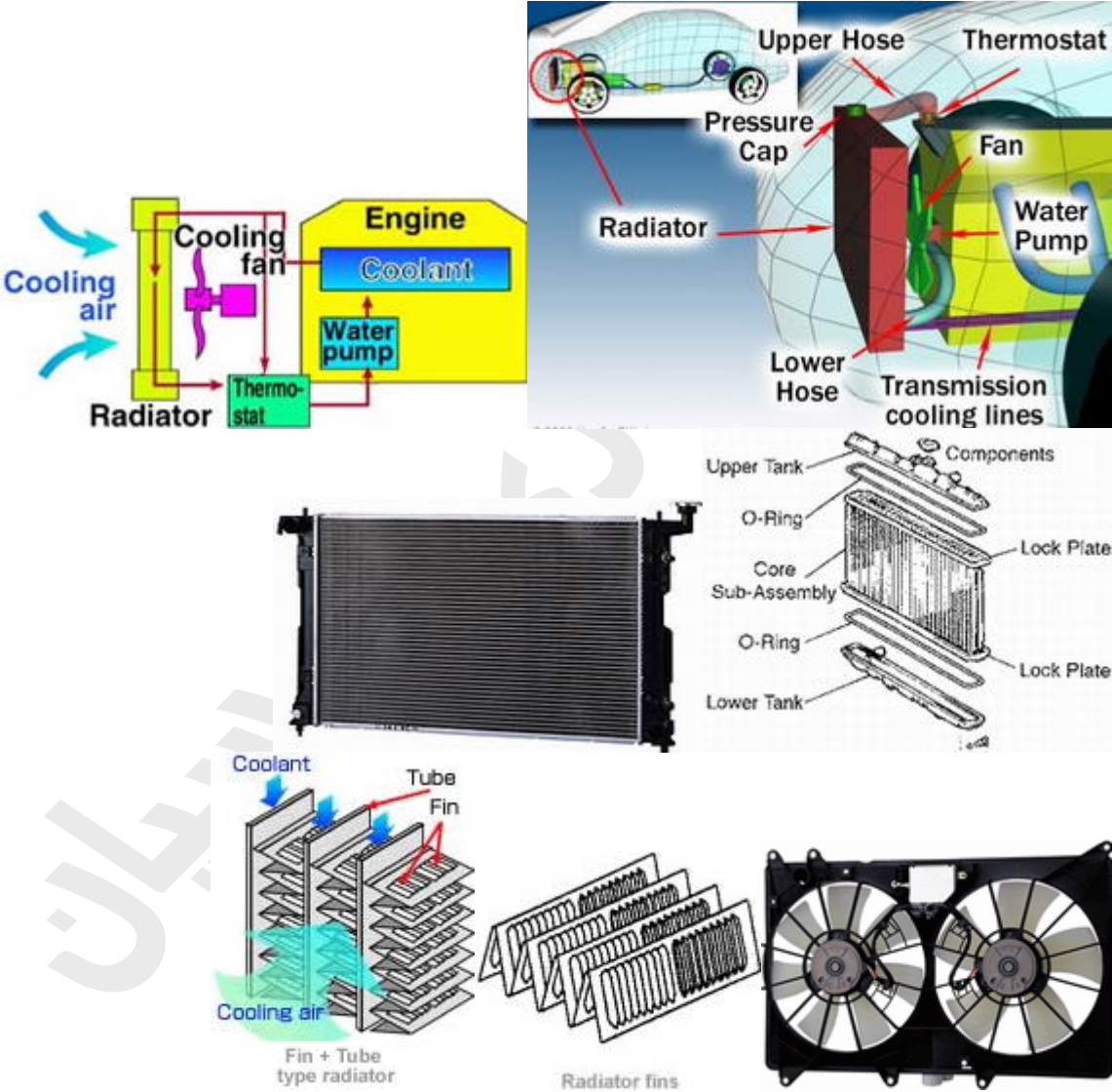

RDS :

Radio Data System

FM

REAL-TIME :

MOZ

ROZ :
Research oktan .

ROADSTER :

ROTARY-WANKEL MOTOR :

Felix Wankel

RX-7

RX-8

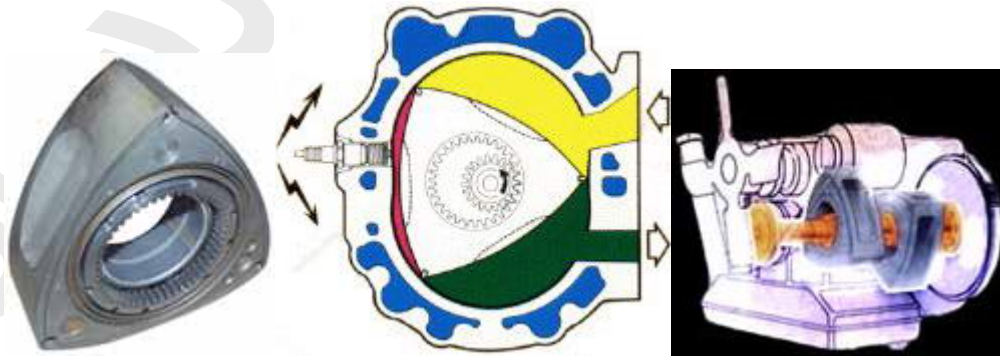

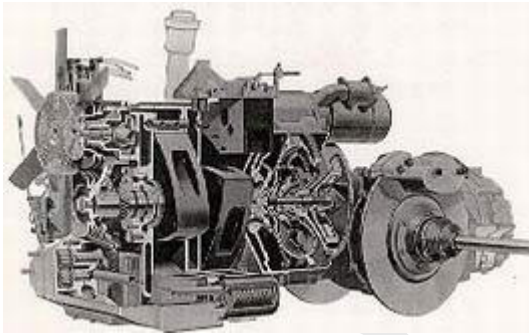
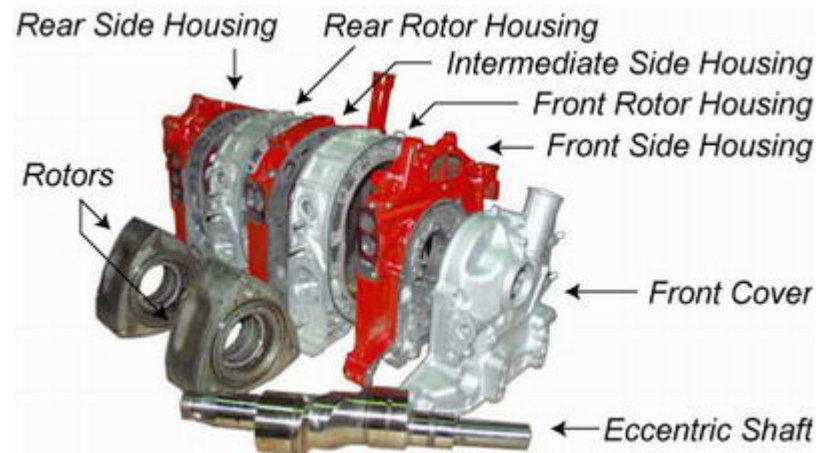

RPM :
Revolutions per Minute

RULMAN :

S

SAE :
Society of Automotive Engineers
()
HP/SAE
HP/DIN

SAHR :
Saab Active Head Restraint.
SAAB

SEDAN :
C

SELESPEED :
() manual Tiptronic

SELF-LEVELLING SUSPENSION :

SETAN :

Road Off

SLS :

SOFT-STOP :

SOFT-TOP :

SPACEFRAME :

A8 , A2 Audi

SOHC :

spoiler :

Spider :

SRS :

STEER BY WIRE :

STOP & GO :
Adaptive Cruise Control (ACC)

SUPER SELECT :

SUV :
SPORT Utility Vehicle.

WD 4

Suspension :



T

GSM

TAS :
Travel Assist System.

S.O.S

TCS :
ASR-ETC.

TDI :
↓ Turbo Dizel Injection



TIPTRONIC :

TPC :

()

TURBO :

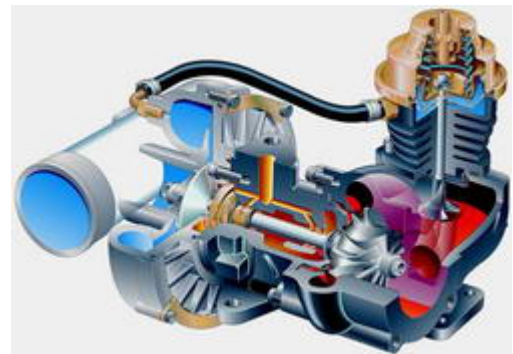
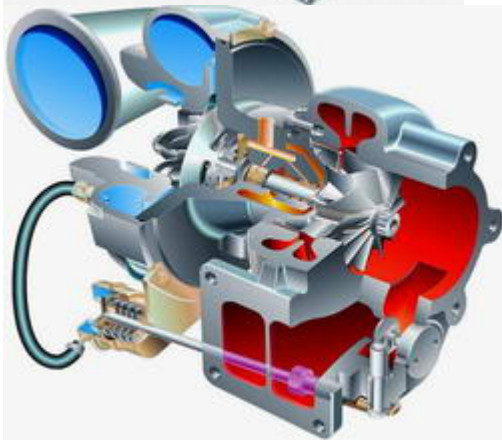
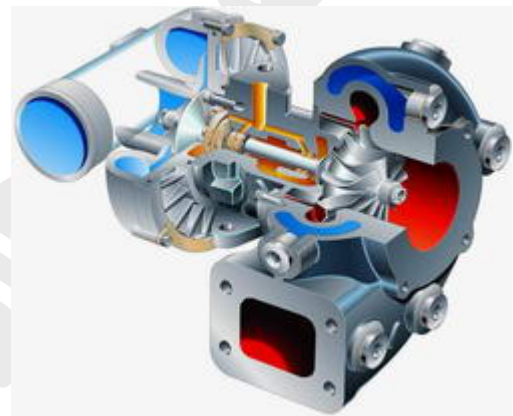
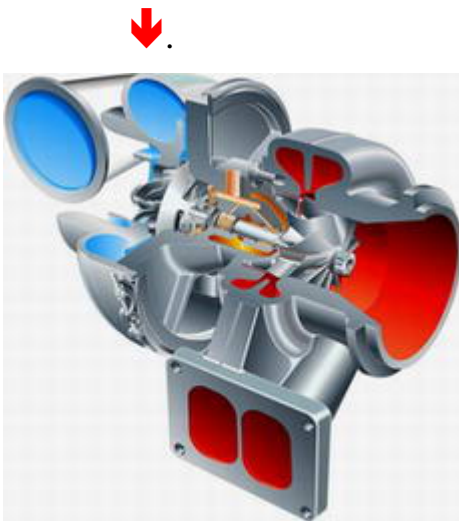

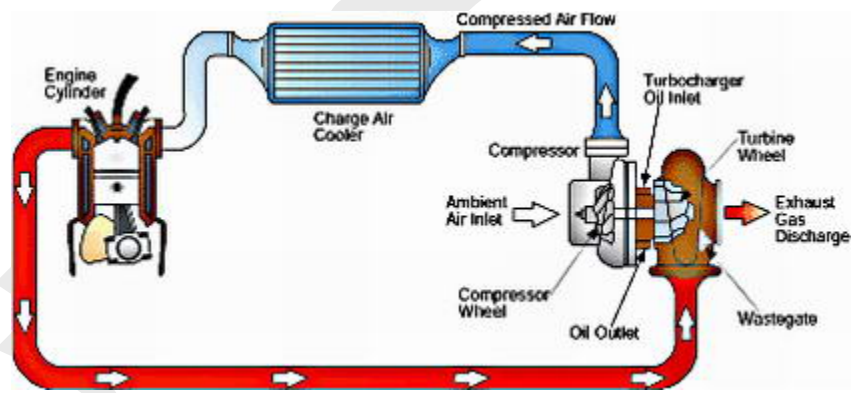
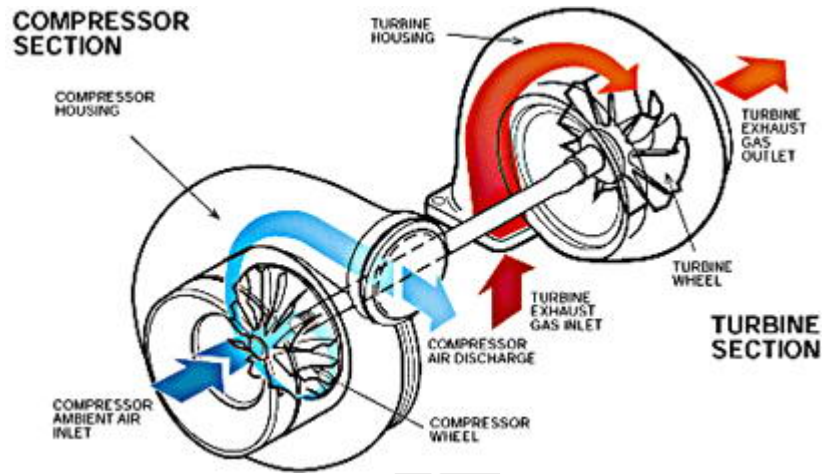

Twin Spark :

.Alfa romeo

سپیان

U

(
↓
)

Understeer :

Result of Understeer. On an understeering car, the rear tires have the greater traction, and tend to push the car toward the outside of a turn.

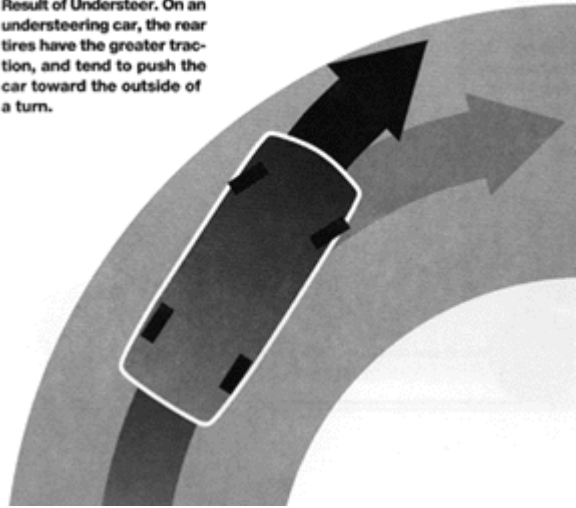

V

BMW

Vanos :

VTEC :

VTG :
Variable Turbo geometry.

).

(

VVT-I :

↓ Toyota



W

WHEELBASE :
()

Euro4

Euro3

(, ,) , , :

(Ecotec)

:
Stork

Easytronic

%

v



شقفل مجازی چار سیپان

mm 4.5

mm 2.5

()

:()

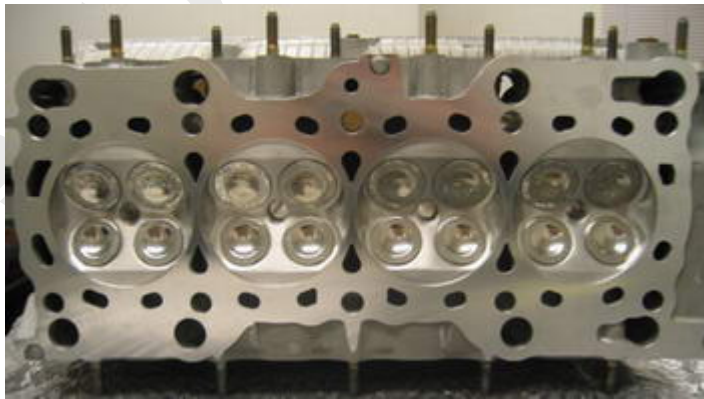

مار سیپان

شغل مجاز



:



, (Handling)

: aerodynamic

(performance)

: Acceleration

: anti-roll bar

sway bar, stabilizer bar anti-roll bar

1 1/8 3/4

(independent suspension systems)

anti-roll bar.

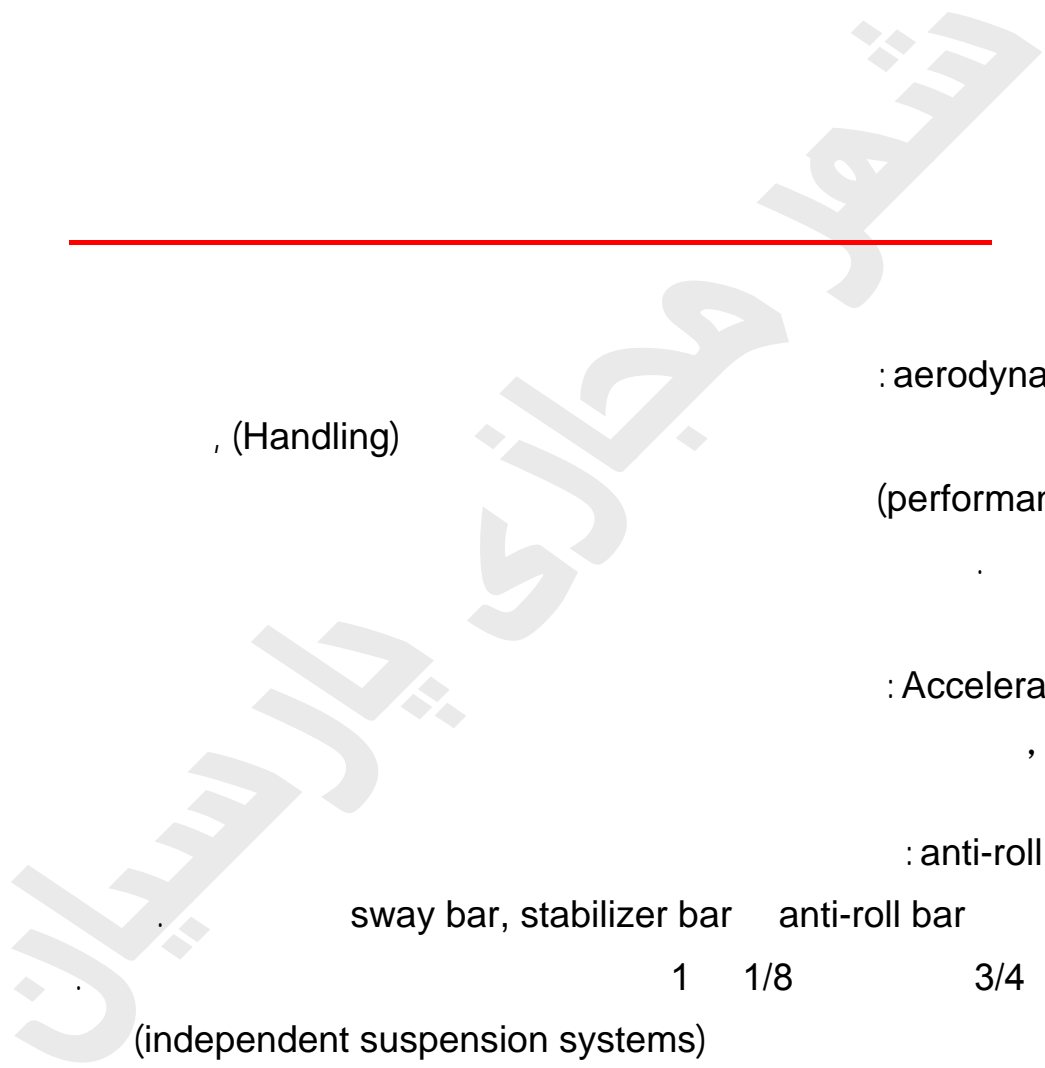



) body roll

Body roll. (

Body roll

body roll

body roll

anti-roll bar

oversteer understeer

neutral balance

: apex

apex



apex

شفق مجازی چارسیگان



: aspect ratio

225*50

(225) 50

: backmarker

Lap

backmarkers

: balaclava

balaclava

balaclava

: balance, handling

Handling balance

() *neutral balance*

four-wheel drift

.(slide)

. understeer push *Tight balance*

, oversteer *Loose balance*

heel-toe downshift

: blip, throttle
, Throttle blip

: blocking

Racing line

Racing

line

Block

: brake bias

spin
30 70

: braking point

: brake turning

trailing-brake Trail braking

() turn-in

(turn-in)

: breathing the throttle

: camber



zero () negative camber
() positive camber
() camber

3/4

3

(zig-zag)

90

: chicane

: chief steward

chief steward

chief steward

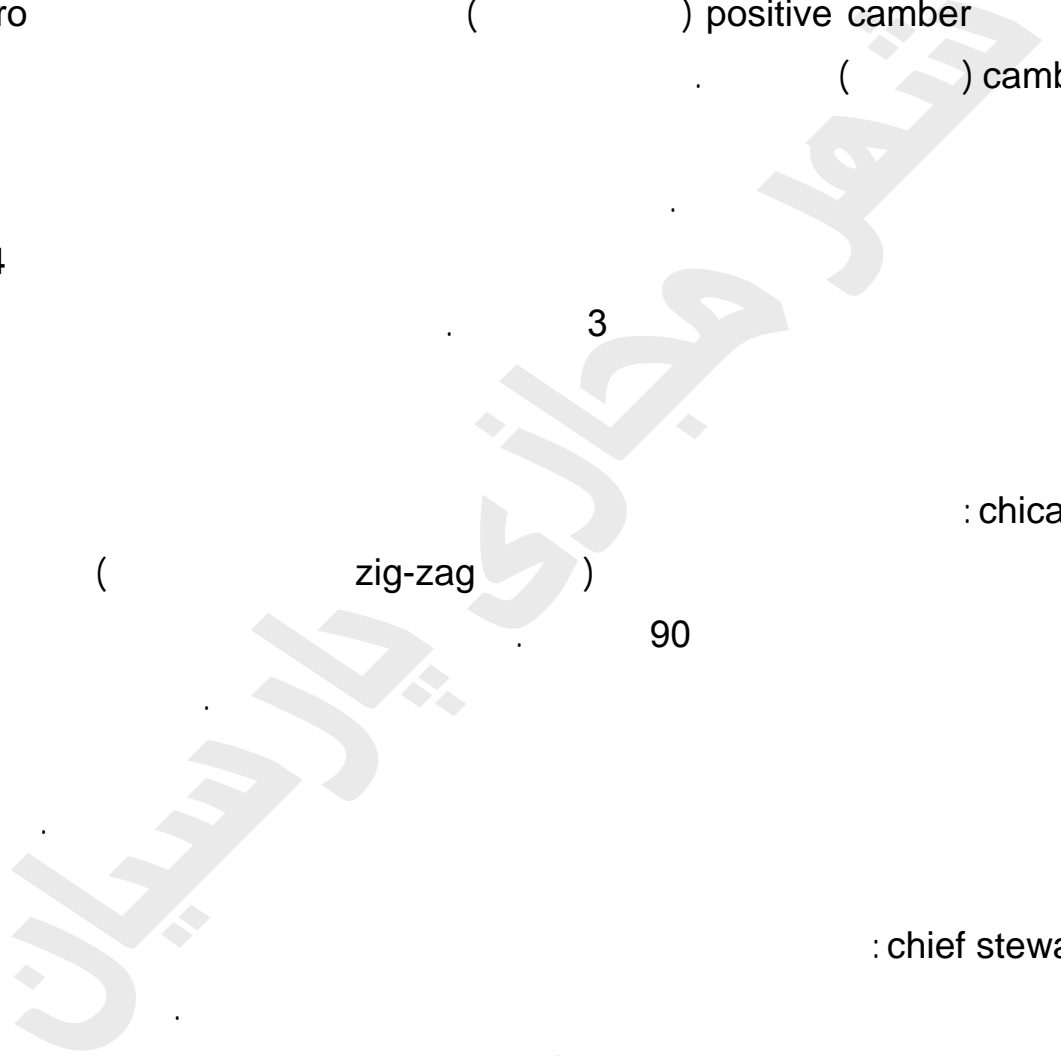



: contact patch, tire
Tire Contact Patch

Tire Contact Patch

(apex ,) entry, apex, exit ,

: corner apex

3

apex

: corner entry

driving line

3

turn-in

entry

Racing line

apex point

: corner exit

exit point apex

)

(.

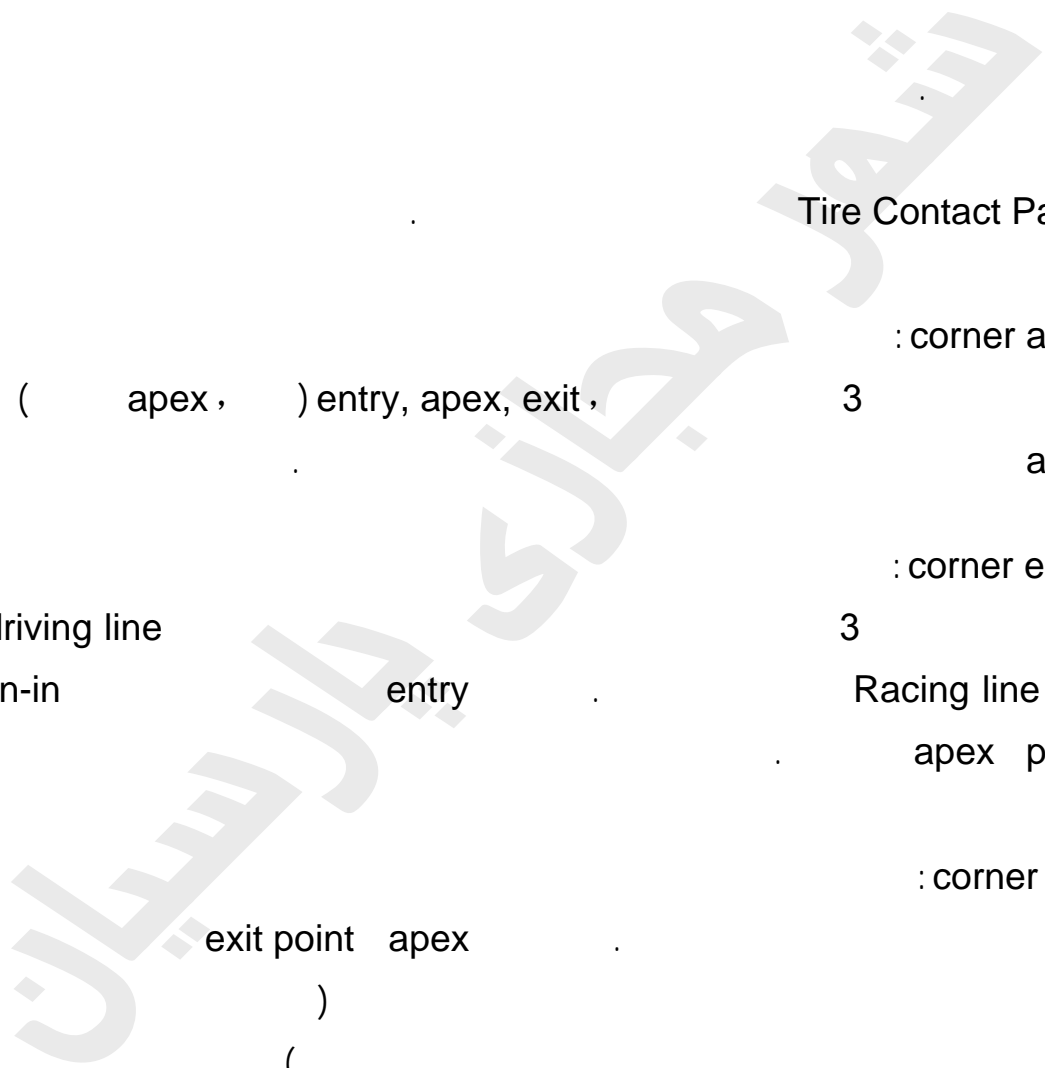



: corner station

(flagman)

Corner station

: corner turn-in

.turn-in point

turn-in point



: corner worker

chief steward

corner worker

: esses

: exit point

apex

() exit point

exit point



: eye path

(reference points)

: FADING
(brake fade)

: Grip

: GT

() Gran Turismo

: oversteer
(loose handling Loose balance)

: Pitlane

.PIT STOP PIT STOP

120

: Pitstop

Race

: Pole Position

lap qualify

Pole Position

: psig psi

.Pounds per Square Inch Guage Pounds per Square Inch

: reference points

: Suspension

: tactile feedback

() race driving

Oversteer

: Spin

Spin

oevrsteer

: understeer

tight handling push

شغل مجازی چارسیان