

New Automatic Transmission for Motorcycles

HFT

Human-Friendly Transmission

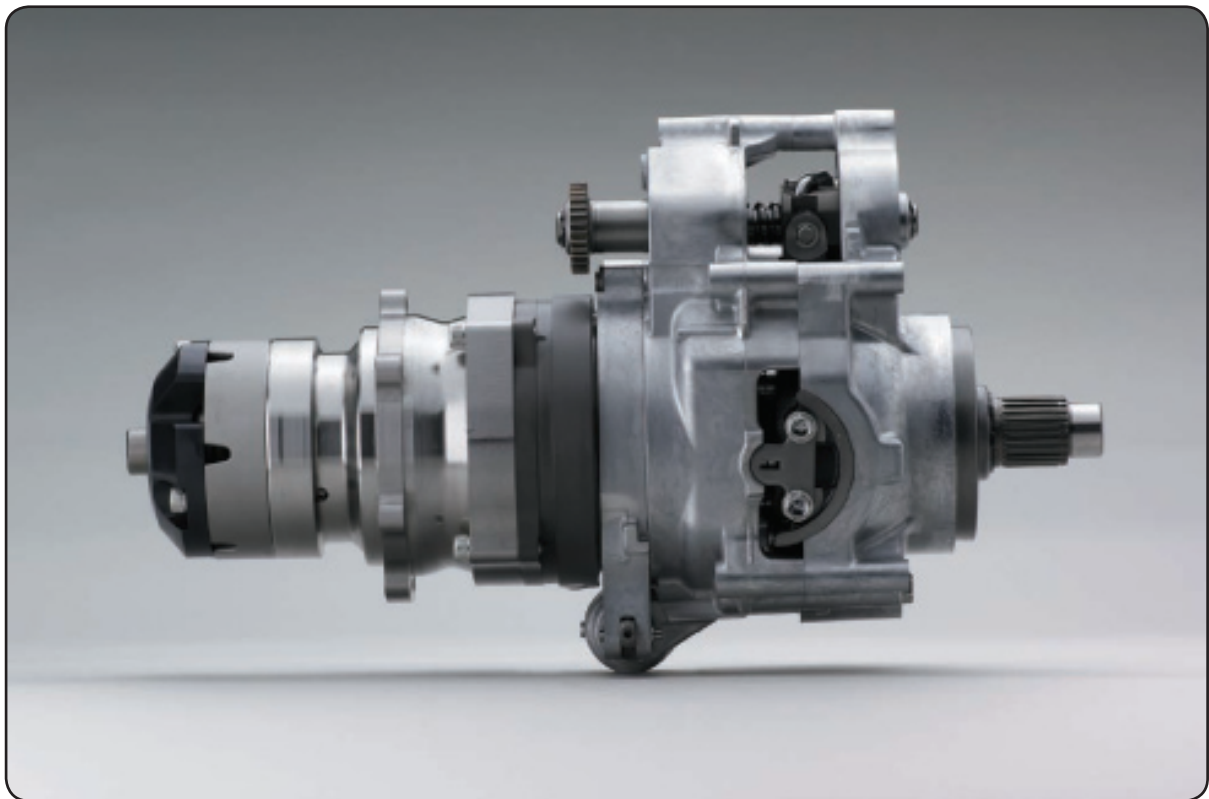

Honda Motor Co., Ltd. has set the environment and safety as two of the most important issues in becoming a leading mobility company, and has committed to a variety of activities. In terms of environmental protection, the company has taken on a series of high-level goals and is expanding application of the programmed fuel injection (PGM-FI) system, which is effective in reducing emissions, to cover most engine displacements, from small to large. Honda is also committed to developing an engine with a cylinder-on-demand system that varies the number of active cylinders in accordance with riding conditions.

For enhanced safety, Honda has increased the scope of application of advanced brake systems such as the Combined Brake System (CBS) and Anti-lock Brake System (ABS) to support improved braking efficiency, considering the specific needs and characteristics of each market and each model. The company has succeeded in developing the first airbag system for mass-produced motorcycles in the world and this system has been launched on the Goldwing in Europe, North America and Japan. Meanwhile, in the area of educational hardware, Honda is cultivating its own unique technologies through such activities as research and development for a regular riding trainer and a riding simulator, which allows riders to effectively learn how to judge and foresee dangerous situations.

Along with these types of environmental and safety activities, Honda is also putting effort into riding pleasure, or in other words, the area of "fun," through the development

of motorcycle technology. With the aim of providing products useful in the everyday lives of customers, Honda has developed and sold motorcycles equipped with easy-to-operate automatic riding technologies. As a pioneer in the era of automatic systems, Honda launched the Super Cub C100 in 1958, equipped with an automatic centrifugal clutch mechanism, which allowed gear shifting without the need for clutch operation. The sports bike Eara (750cc), released in 1977, was the first large-sized motorcycle in Japan to feature a torque converter.

In 1980, Honda put the Tact on the market, a machine equipped with the Honda-original continuously variable transmission, the V-Matic, and Honda has continued to develop a variety of new mechanisms up into the present.

Currently, scooters are the focus for automatic transmission use, but, for the motorcycle, with its popularity as a hobby machine in Japan, the U.S. and European countries, Honda believes that there is a demand for even easier operation in shifting with the automatic transmission and that desire for automatic transmissions will increase from now on, even for very sporty models. Honda has been involved in the development of new automatic systems suitable for these sporty motorcycles for many years and is certain that the DN-01 with the Human-Friendly Transmission (HFT) presented here will open new horizons for motorcycle enthusiasts worldwide.



*DN-01
(Scheduled for exhibition at the 40th Tokyo Motor Show)*



*HFT
(Human-Friendly Transmission)*

The key concept in the development of the DN-01 was relaxed and easy operation with a luxurious feel and striking uniqueness.

To realize this concept, the Human-Friendly Transmission (HFT) was adopted. Incorporating a lockup mechanism and start clutch for even more compactness and improved efficiency, the major features of the system include:

- A compact unit increasing machine design freedom
- Highly efficient torque transmission due to mechanical transmission in parallel with hydraulic transmission
- Simple system configuration and high level of controllability

The compact unit increases the degree of freedom in designing the motorcycle and the highly efficient torque transmission allows a ride feel unique to motorcycles, while the various built-in shifting modes provide easy and sporty riding pleasure.

Innovative design

Ride feel unique
to motorcycles



Easy operation

The HFT consists of an oil pump for converting engine power into hydraulic pressure, and an oil motor for converting the hydraulic pressure back into power for output.

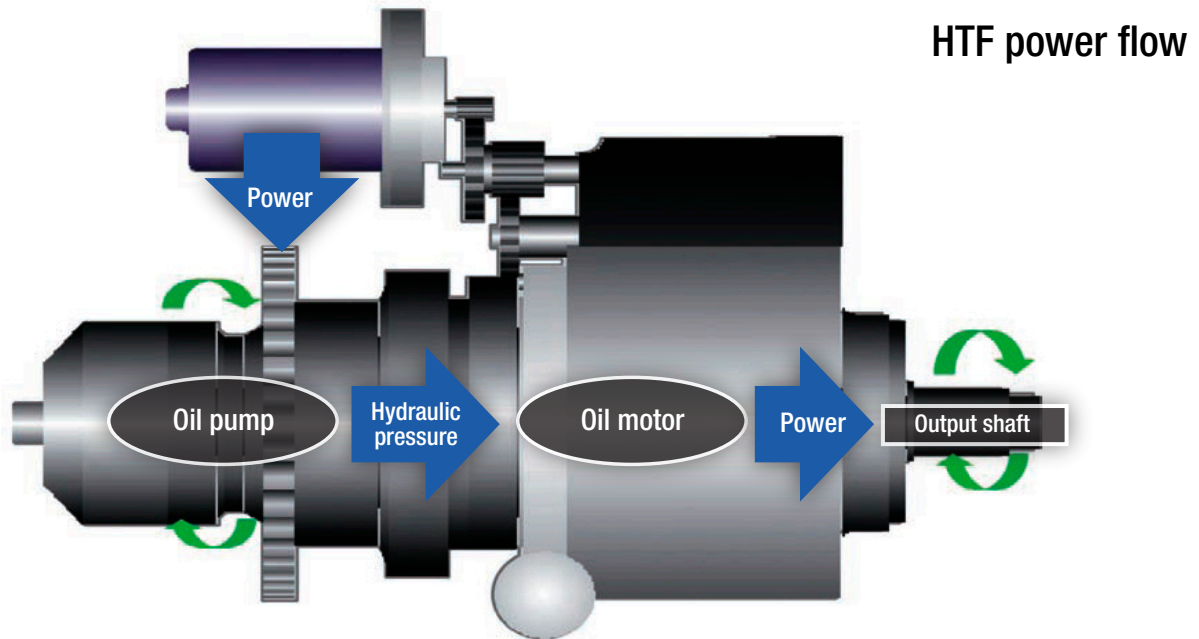

The red area is the oil pump and the blue is the oil motor. The oil pump and motor each have swash plates and pistons with a cylinder between the pump and the motor connected by the pistons. An output shaft is incorporated into the cylinder. The inclination of the pump swash plate is fixed, while the motor swash plate inclination is variable.

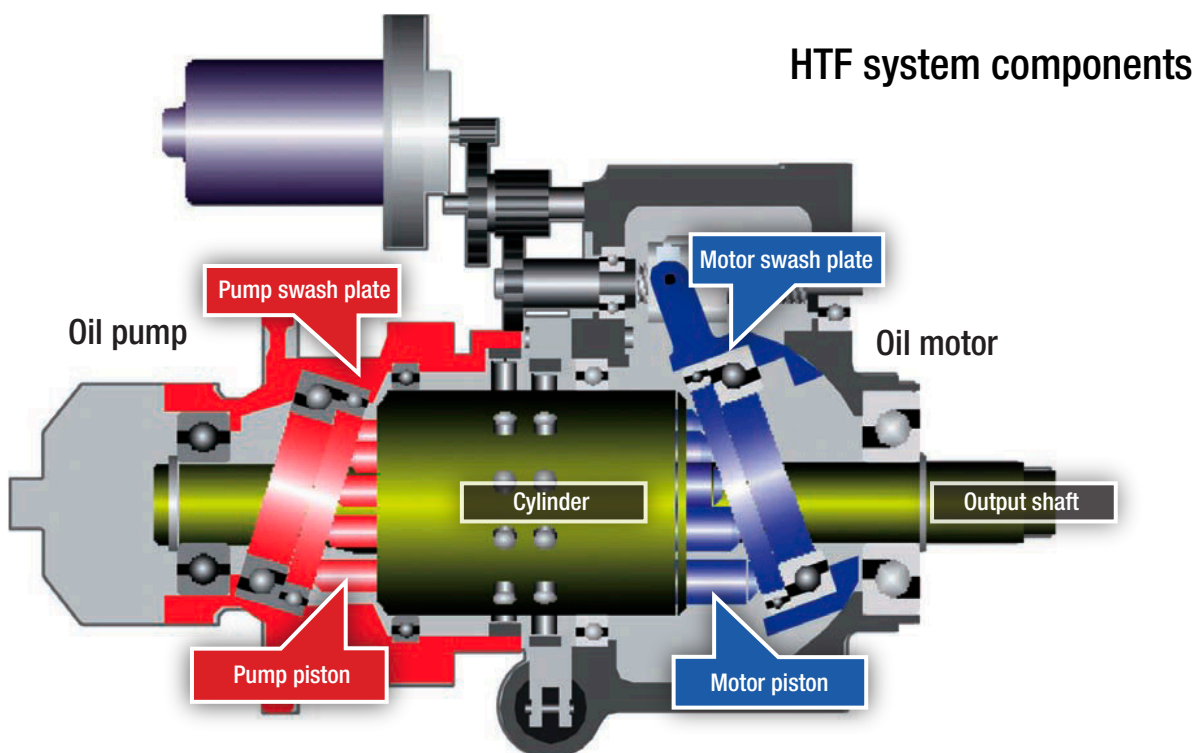

High-pressure fluid flow

The engine rotates the pump swash plate, which has a gear mechanism. The rotating swash plate pushes the pump pistons to increase the pressure on the hydraulic fluid and feed it to the high-pressure annular chamber. The high-pressure fluid is then fed to the oil motor piston chamber where it pushes the pistons forward, which then push the motor swash plate.

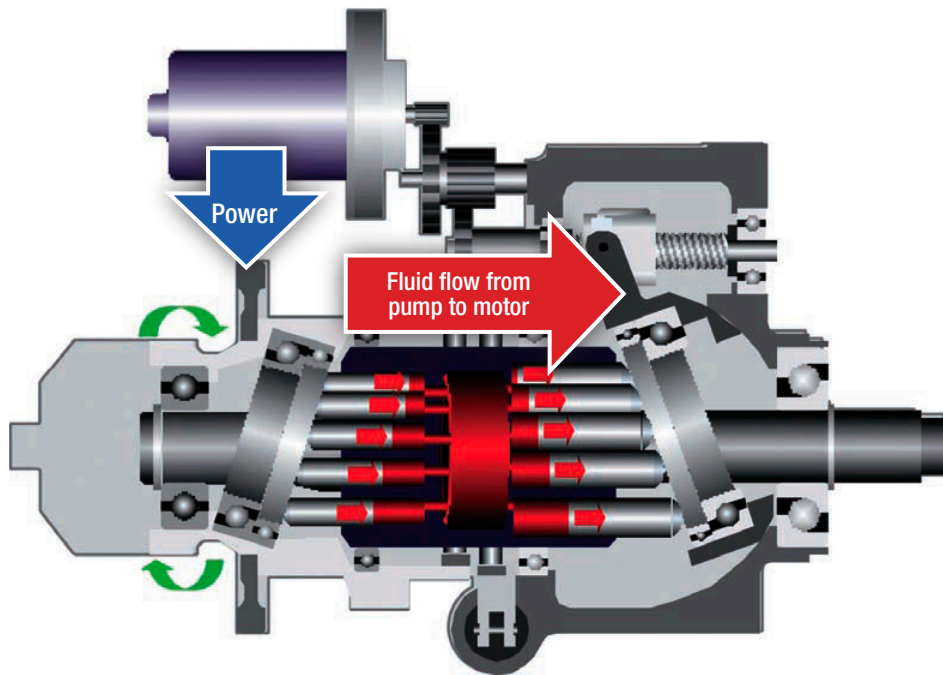

Low-pressure fluid flow

The lower-pressure hydraulic fluid returns to the pump through the low-pressure annular chamber. In this way, the fluid circulates between the pump and the motor.

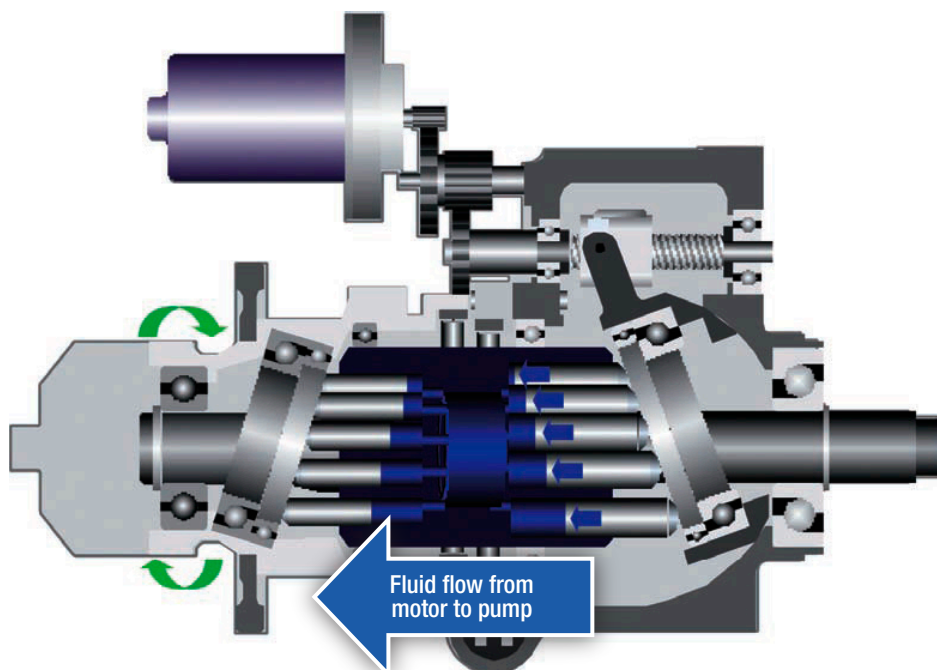

Movement of distributor valves and pistons

The distributor valves play an important role in fluid circulation. The valves are placed both in the oil pump and motor. When the pump pistons move to the compression side, the valves connect the piston chamber and the high-pressure chamber. When the pump pistons move to the expansion side, the valves allow a connection between the piston chamber and the low-pressure chamber. The valve in the oil motor moves opposite to its counterpart in the pump, ensuring the circulation of fluid within the system.

Movement of oil pump distributor valve

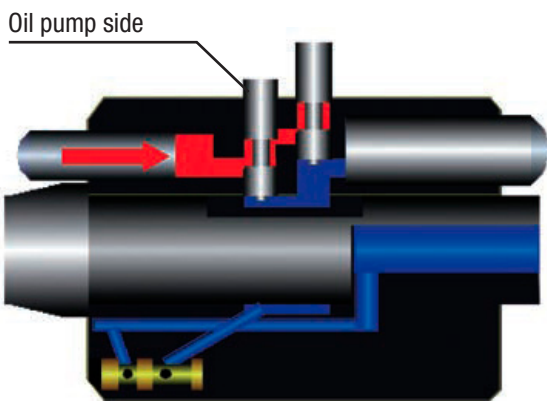

Pistons move to compression side
 > Fluid pressure-fed to high-pressure chamber

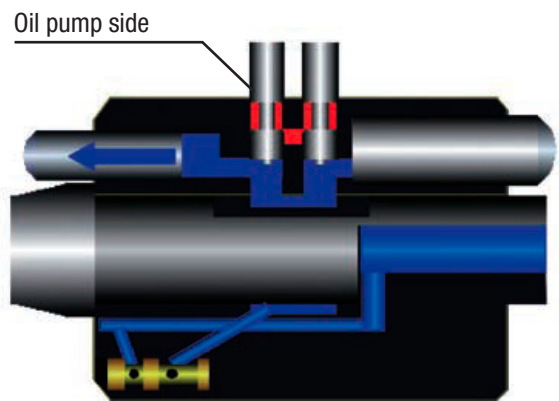

Pistons move to expansion side
 > Fluid enters from low-pressure chamber

Movement of oil motor distributor valve

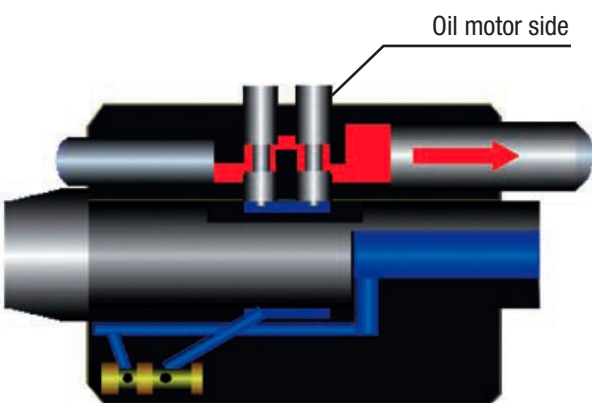

Pistons move to expansion side
 > Fluid enters from high-pressure chamber

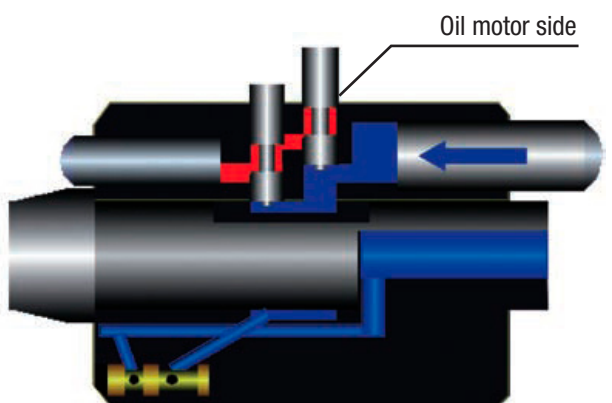

Pistons move to compression side
 > Fluid returns to low-pressure chamber

The distributor valves ensure constant conversion of the engine's output torque to high hydraulic pressure power. The reaction to the hydraulic power is then converted to torque that rotates the cylinder, while the movement of the distributor valves is regulated by an eccentric ring, for system simplicity and constant, stable operation.

When they are pressed through the swash plate, the oil pump pistons compress the hydraulic fluid to feed to the high-pressure chamber. The high-pressure fluid then generates pushing force which acts on the pump and motor pistons and each piston receives downward reactive force from the swash plate. With the pistons connected to the cylinder, the reactive force generates rotating force (torque) that drives the cylinder and the output shaft incorporated into the cylinder.

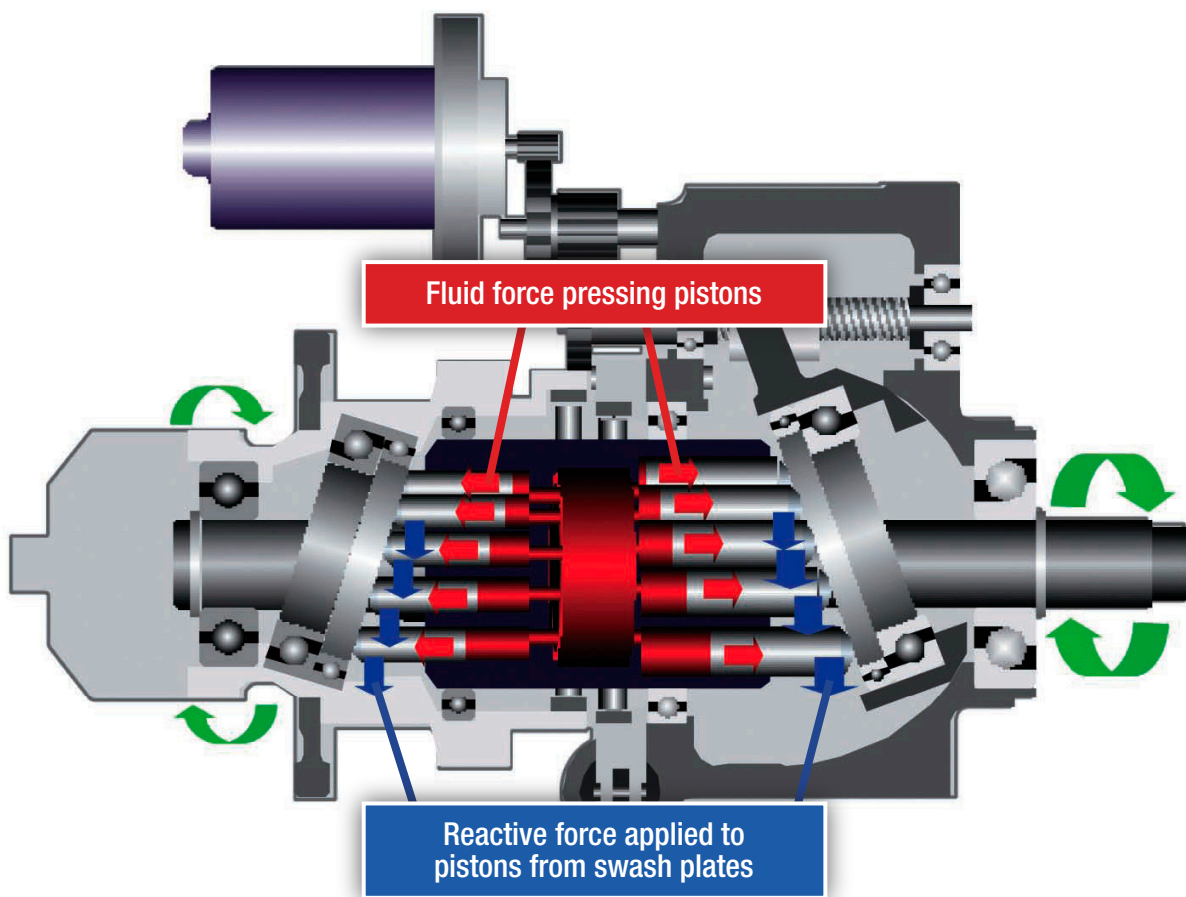

Motor swash plate movement and torque transmission

The torque available depends on the angle of the swash plate. The oil pump generates constant torque because the inclination of its swash plate is fixed. However, torque generation may be varied by altering the angle of the swash plate incorporated into the motor. The output torque is at a maximum when the motor swash plate is set at the maximum inclination. When the angle is decreased, the torque also decreases. With a perpendicular setup, the oil motor does not generate torque and the only available torque is that directly transmitted by the oil pump.

Motor swash plate at maximum inclination
> Maximum torque transmission

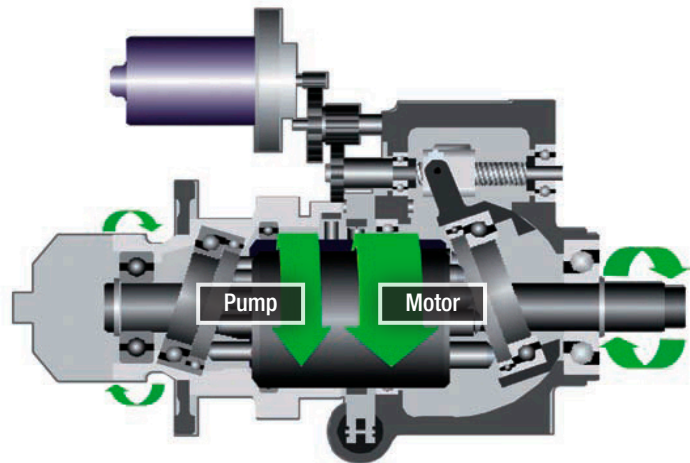

Motor swash plate at medium inclination
> Medium torque transmission

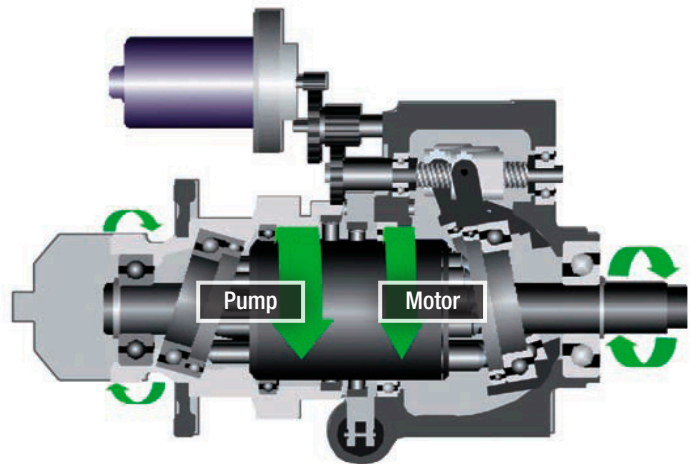

Motor swash plate with no inclination
> Minimum torque transmission

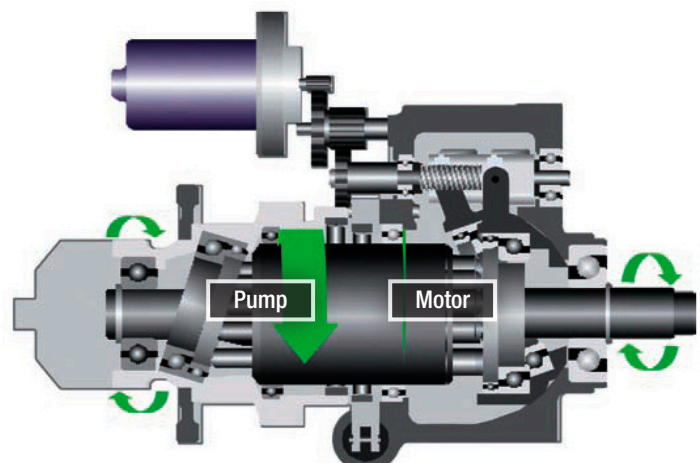

Motor swash plate movement and gear ratio

One function of the oil motor is varying the gear ratio by changing the inclination of the swash plate and the resultant amount of fluid required by the motor. The amount of fluid required by the oil motor side creates the difference in rotation between the pump swash plate and cylinder. When this difference is largest, the gear ratio is lowest. When there is no difference, the ratio is at its highest.

Low ratio

With a large motor swash plate inclination, a large amount of fluid is required, corresponding with the larger strokes of the motor pistons. Therefore, the rotational difference between the pump swash plate and the cylinder (output shaft) grows larger so that the pistons move faster. The ratio is thus at its lowest when the inclination of the motor swash plate is at a maximum.

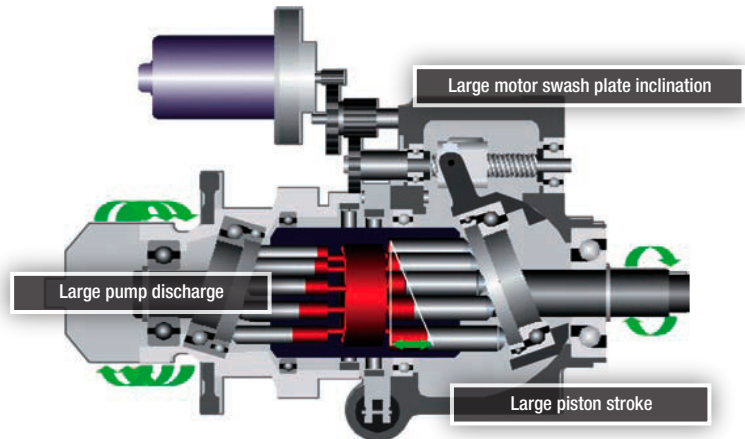

Medium ratio

As the motor swash plate angle is gradually reduced, the amount of fluid required for motor piston operation decreases. The rotational speed of the output shaft increases and the rotational difference between the shaft and the pump swash plate decreases. Here, the gear ratio varies continuously.

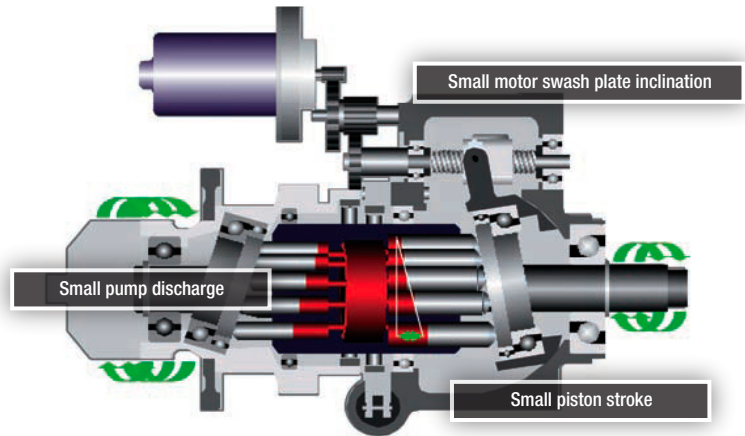

High ratio

With no motor swash plate inclination, there is no motor piston stroke and thus hydraulic fluid is no longer required. The rotational speed of the pump swash plate becomes the same as that of the cylinder (output shaft), resulting in the highest ratio (gear ratio of 1.0).

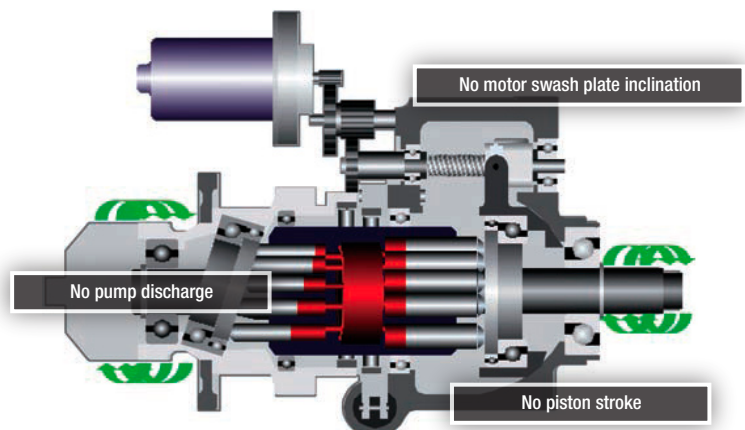

An electronic device was adopted for HFT shift control. The electronic control unit (ECU) regulates control motor operation based on various information such as engine speed and throttle setting. The rotation of the control motor is converted to a linear motion by a ball screw, varying the inclination of the motor swash plate. To meet diversified rider needs, HFT offers two fully automatic shifting modes—D mode for ordinary riding and S mode for a sporty riding experience—or the 6-speed manual mode, which gives riders the option of riding with a manual transmission feel. Riders can then switch among the three modes in accordance with their preferences.

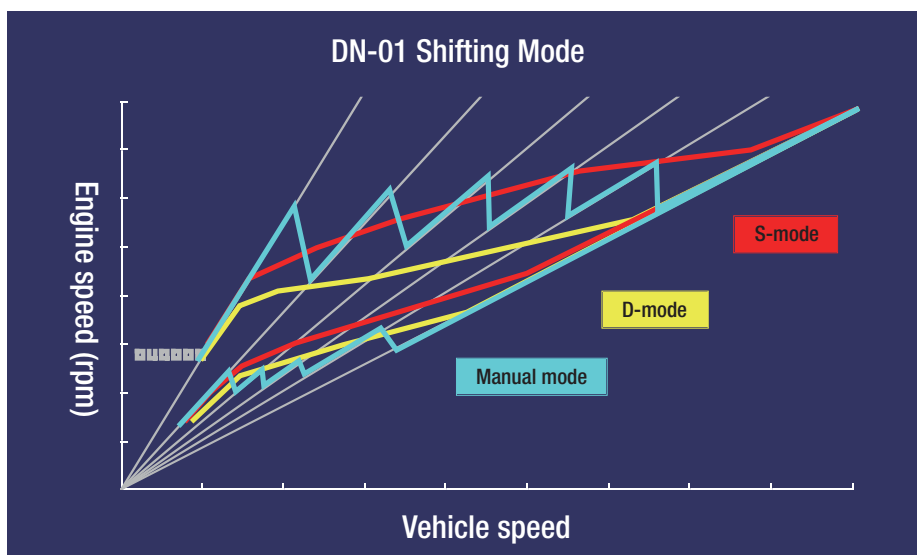
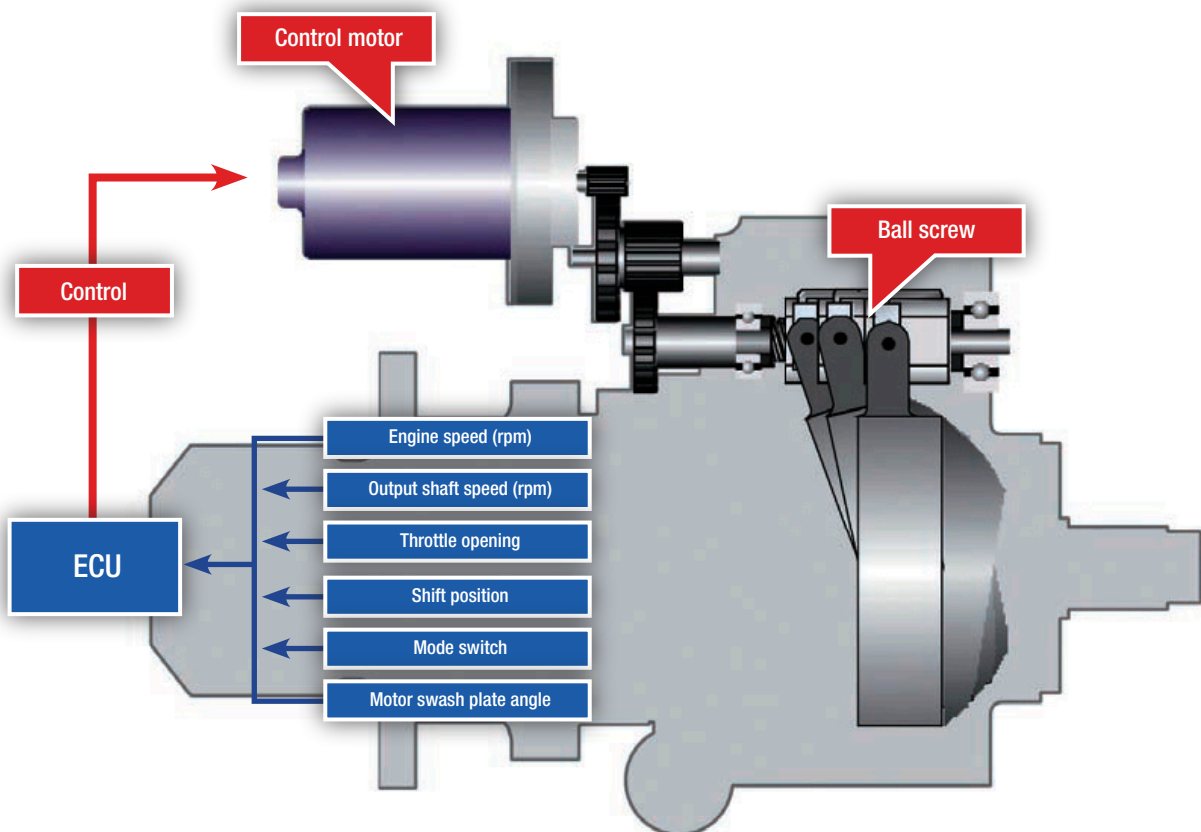

At the highest ratio, there is no torque transmission from the oil motor, but losses due to friction and fluid compression occur with circulation of the high-pressure hydraulic fluid. To minimize losses while improving transmission efficiency, the HFT is equipped with a lockup mechanism. The structure is such that the mechanism begins to operate when it detects that the highest gear has been selected, and the distributor valve blocks the path of the high-pressure fluid to the oil motor piston chamber.

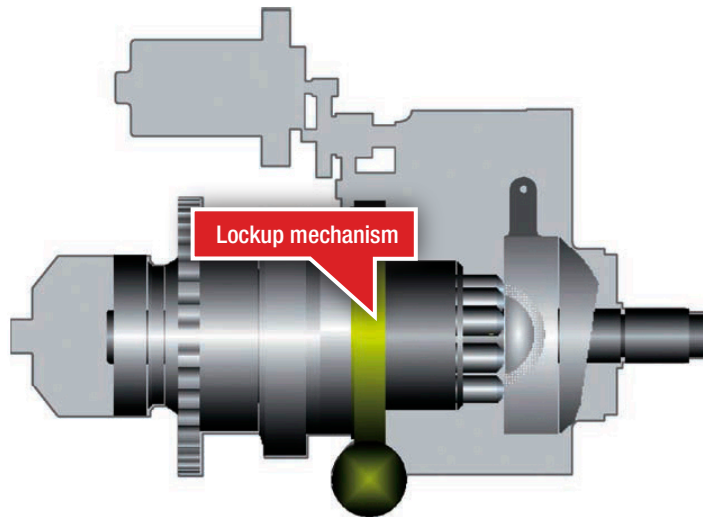

When the lockup mechanism is idle, the distributor valve moves with the eccentric ring in the outer perimeter and switches between the piston and the high and low-pressure chambers. At the highest ratio, the hydraulic actuator cancels the eccentricity of the perimeter ring and the distributor valve blocks the fluid path between the high-pressure and piston chambers, causing lockup conditions.

When the lockup mechanism is off

When the lockup mechanism is on

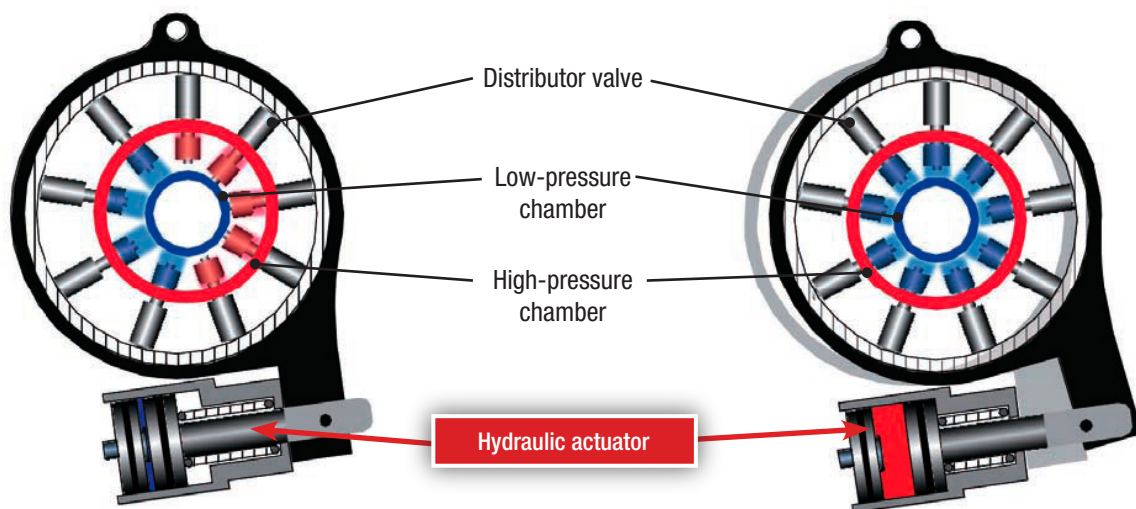

The stroke of the distributor valve switches the piston chamber hydraulic pressure.

The fluid path between the high-pressure and piston chambers is blocked and there is no distributor valve stroke.

The hydraulic actuator carrying out for the lockup function is controlled electronically. According to information on engine speed, output shaft speed and swash plate angle, the system ECU determines if the highest ratio has been engaged and allows fluid flow from the external oil pump to the solenoid valve to change the eccentric ring placement.

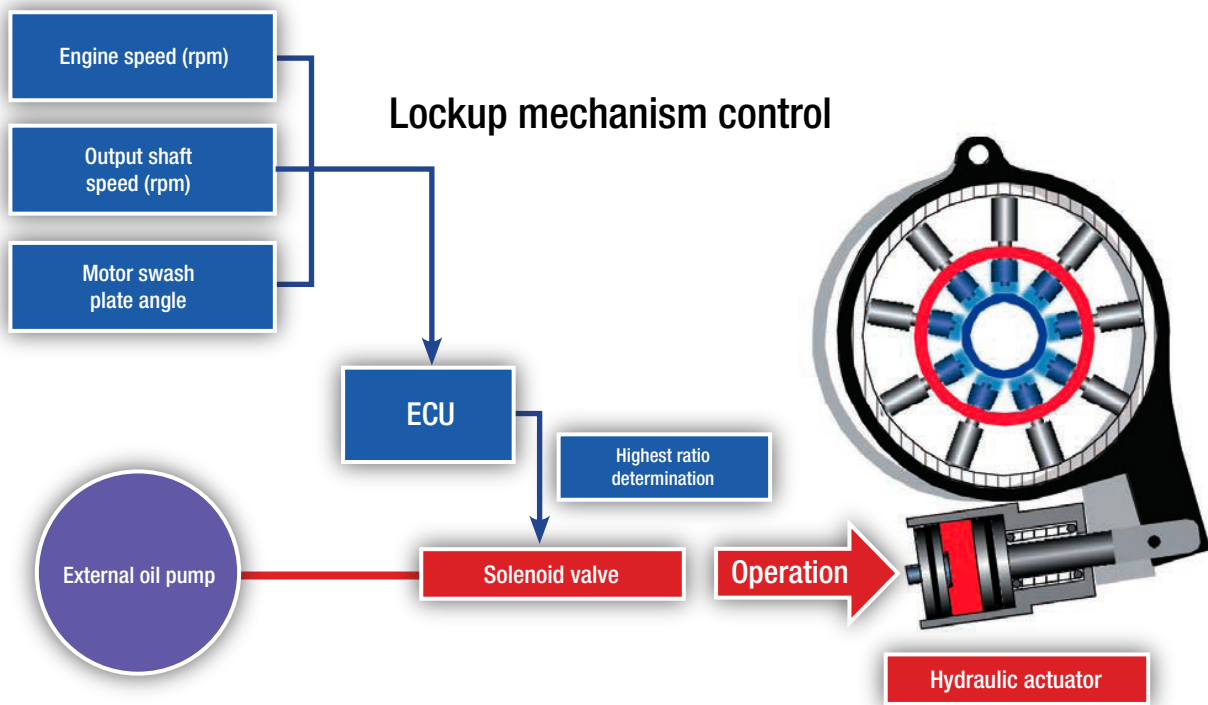

Smooth starting and stopping, along with overall system compactness has been realized by combining a compact hydraulic start clutch with the HFT.

The start clutch consists of:

1. A clutch valve connecting the high and low-pressure chambers
2. A centrifugal governor that operates the clutch valve through engine rpm

The centrifugal governor rotates with the oil pump swash plate.

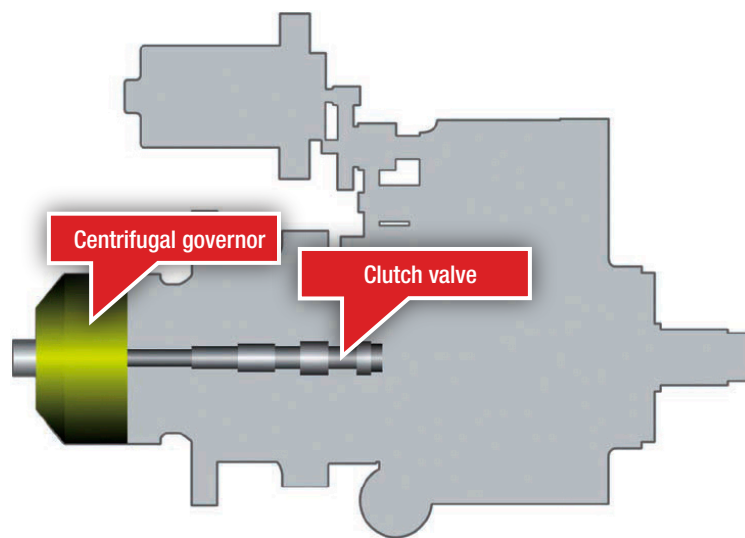

The weights inside the governor expand outward due to the centrifugal force resulting from the increased rotation of the pump swash plate, which pushes the connected clutch valve inward. When rotation decreases, spring force returns the clutch valve to its original position.

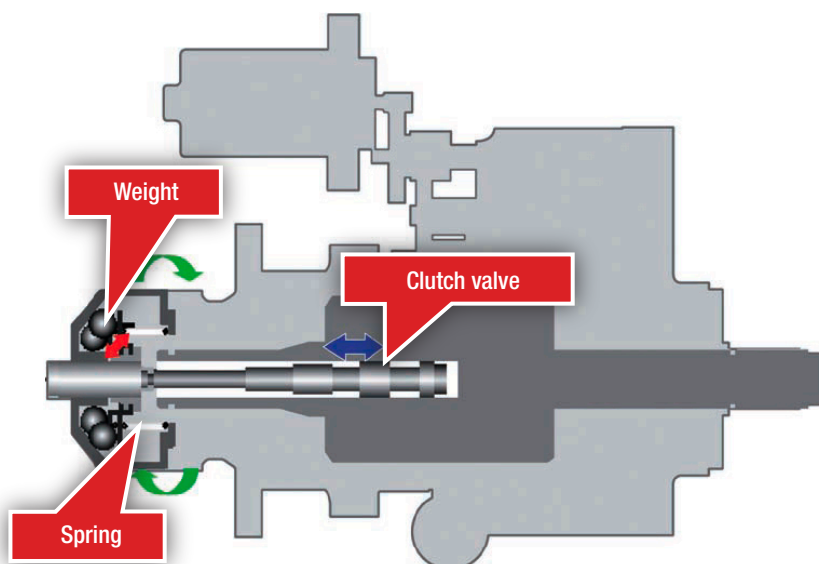

As the governor moves, the clutch valve moves inside the hollow shaft to connect and disconnect the high and low-pressure chambers. When the two chambers are connected, because fluid pressure is released into the low-pressure chamber, no torque is transmitted and the clutch remains disengaged. When the two chambers are disconnected, fluid pressure, torque is transmitted and the clutch is engaged. Since the clutch is operated by regulating hydraulic pressure, taking full advantage of the characteristics of the HFT, start clutch operation is smooth.

